

F.o.G 9/65 - 11/68

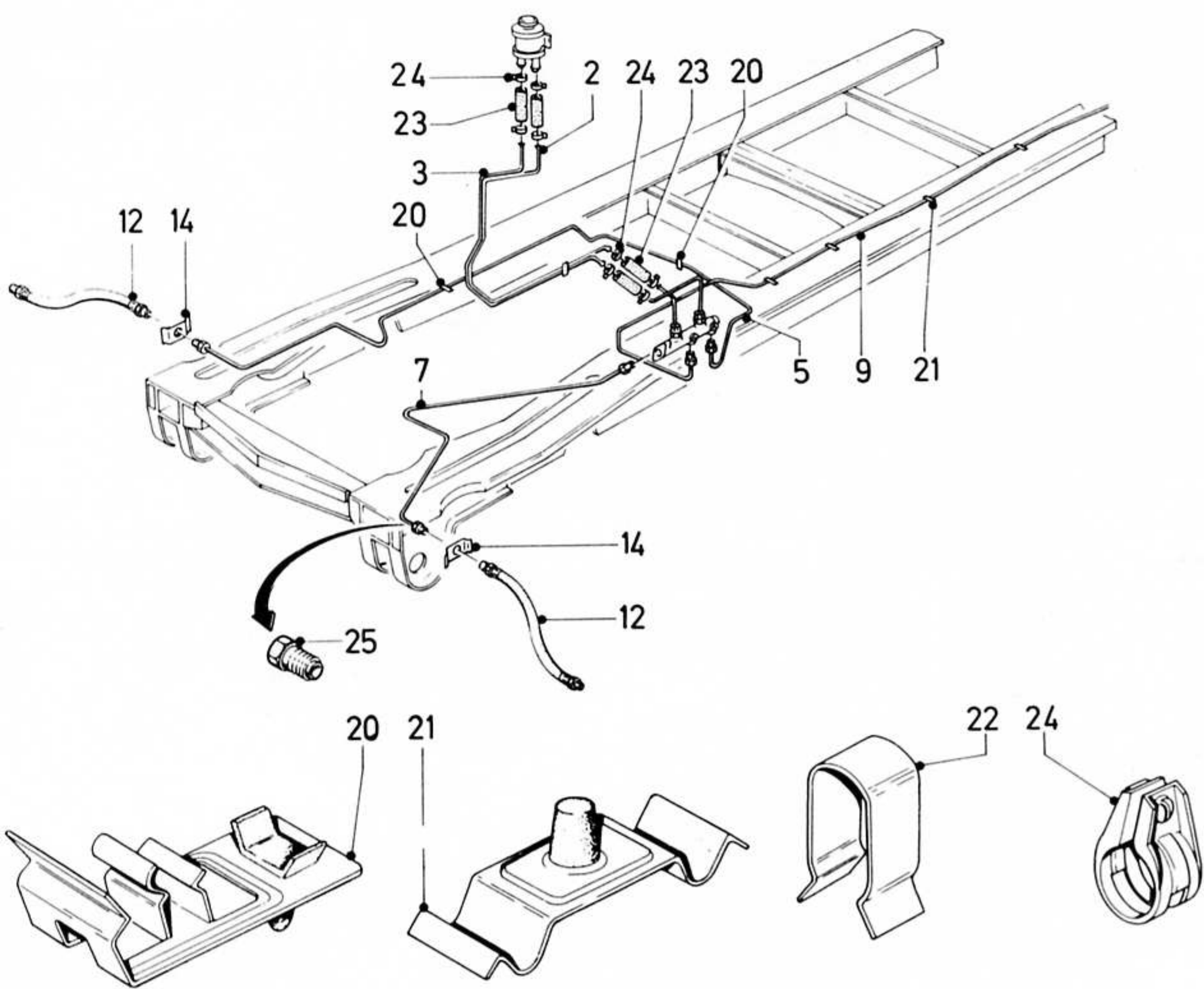

F.o.G 09/65 - 11/68

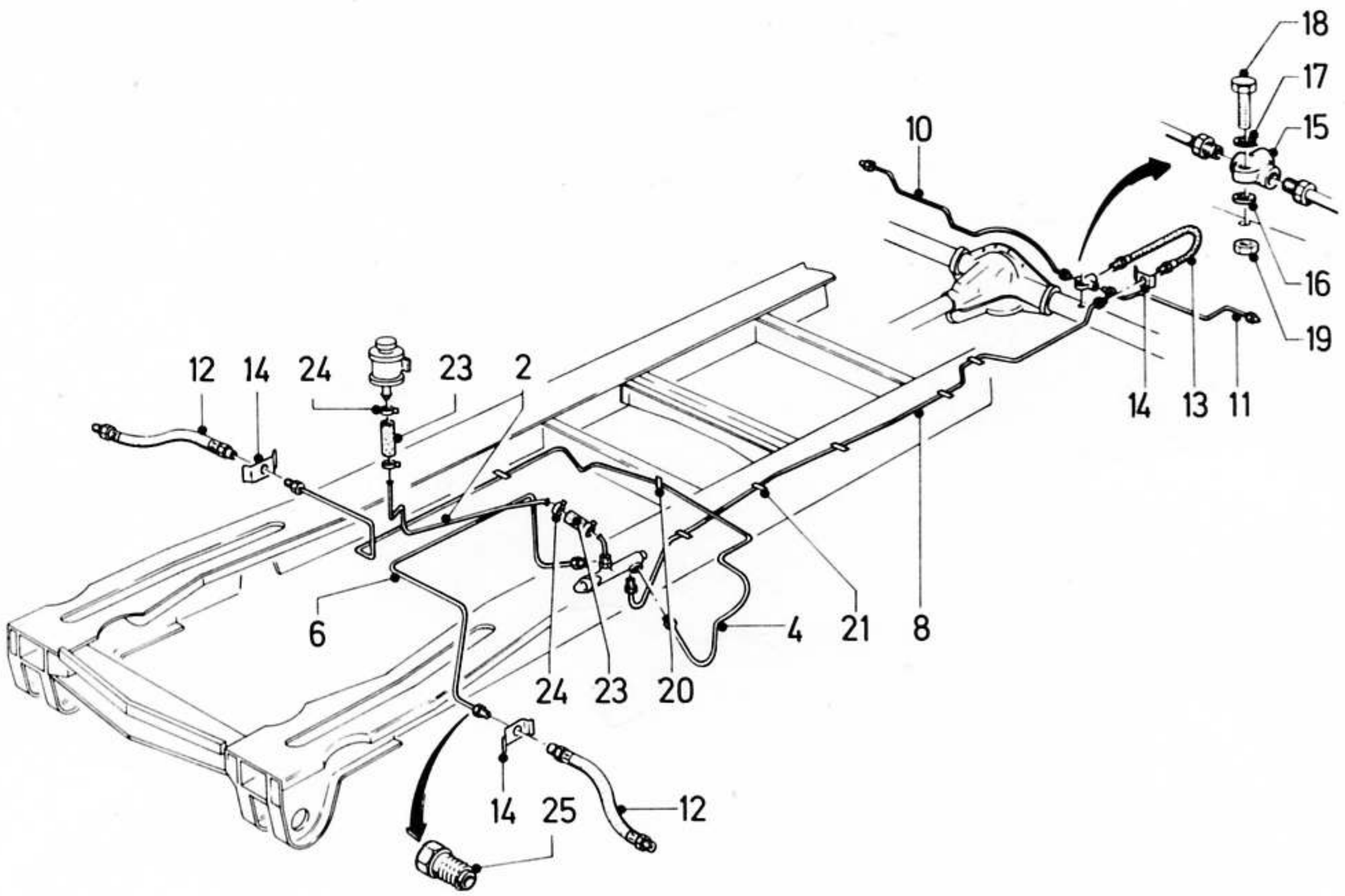
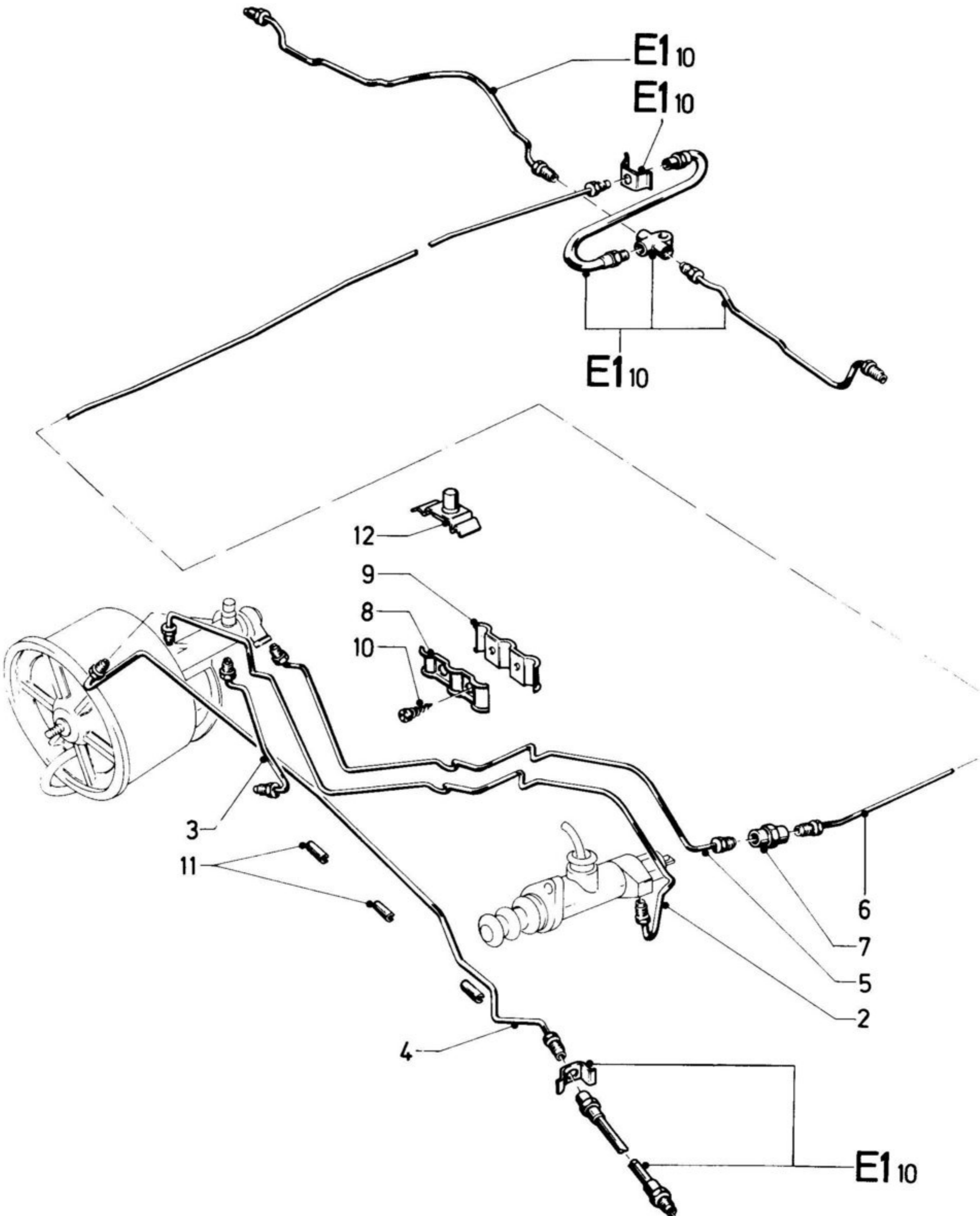

F.o.G. 11/68 12/70

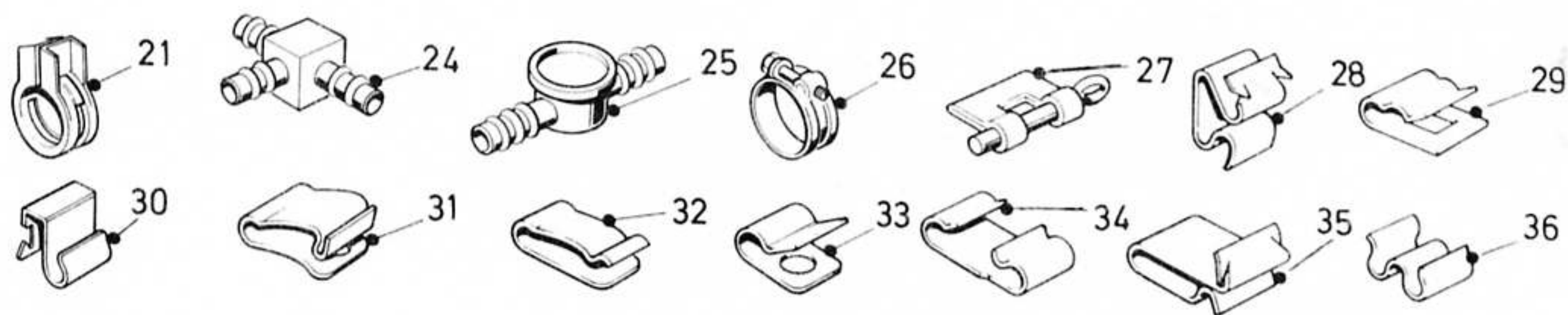
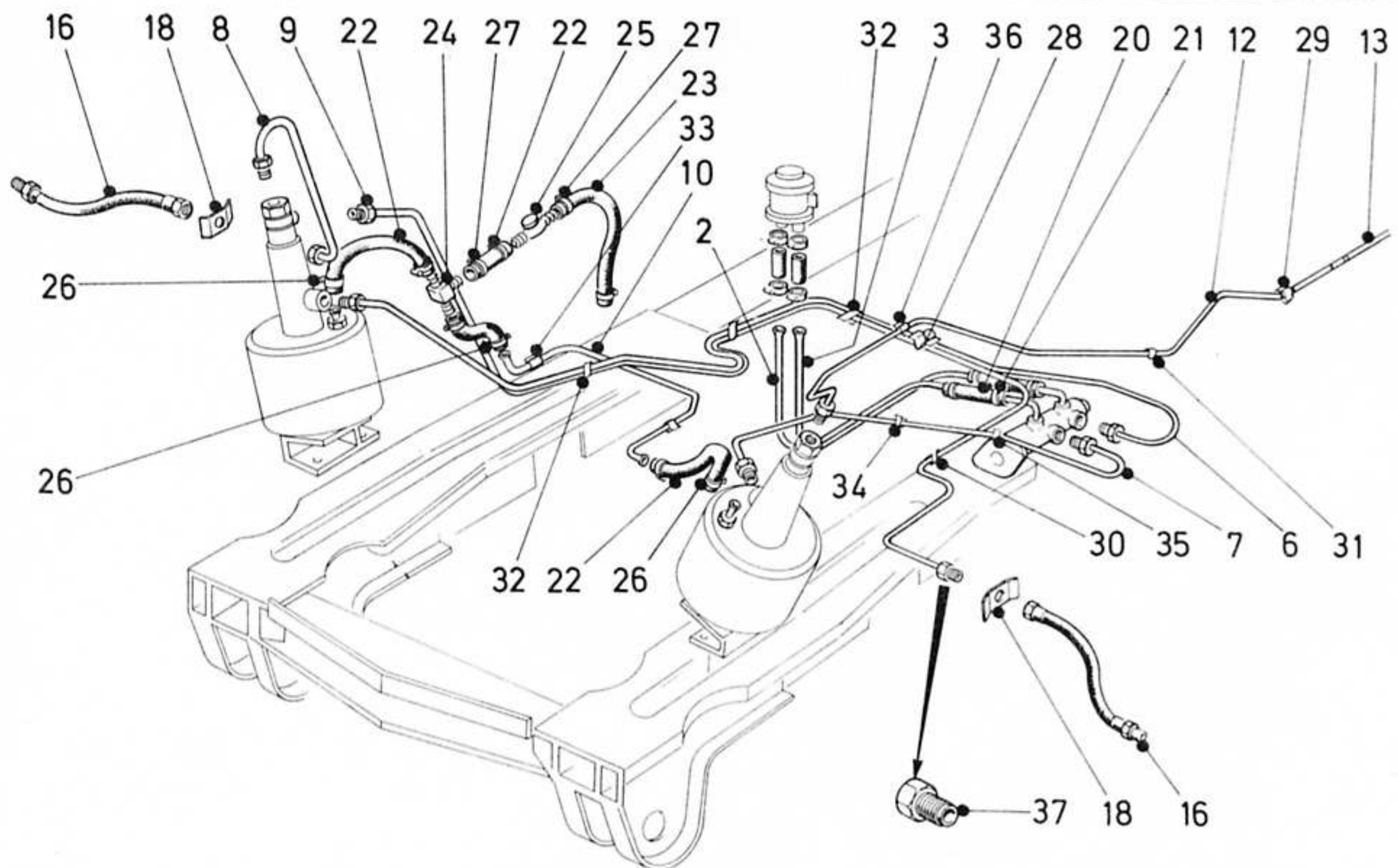
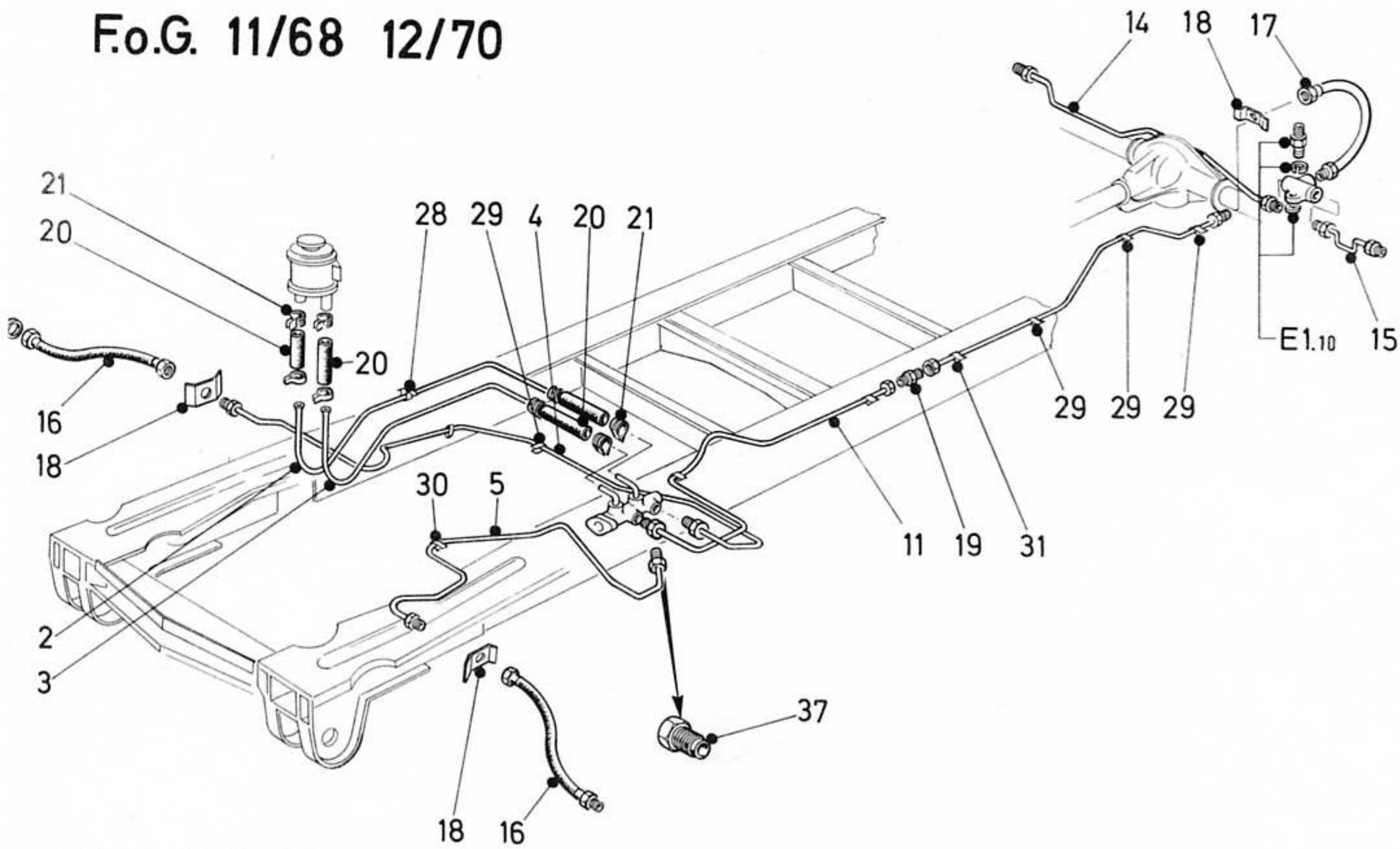

F.o.G 12/70-

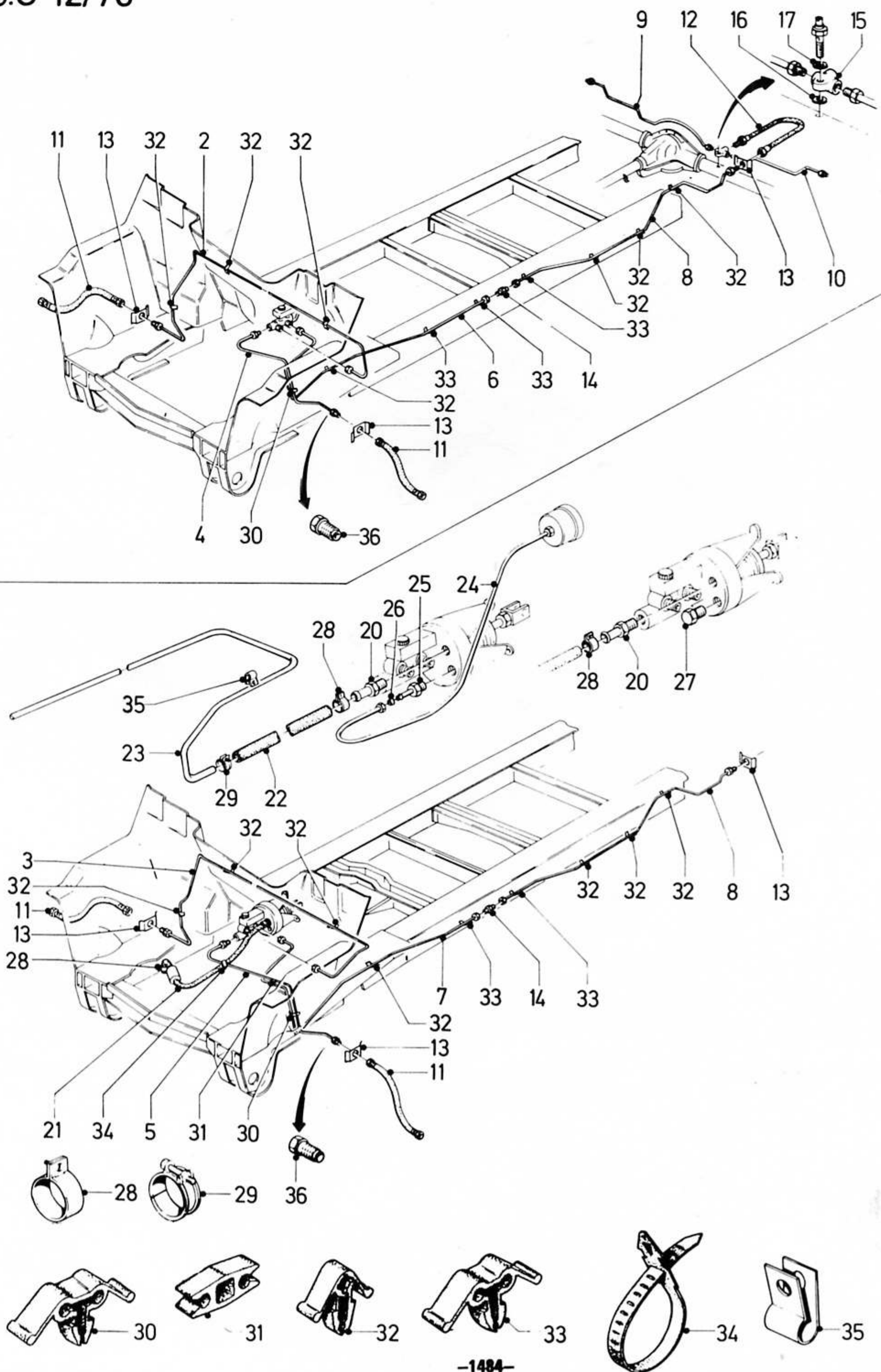

Fo.B 08/65-09/68

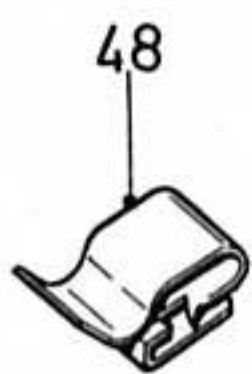
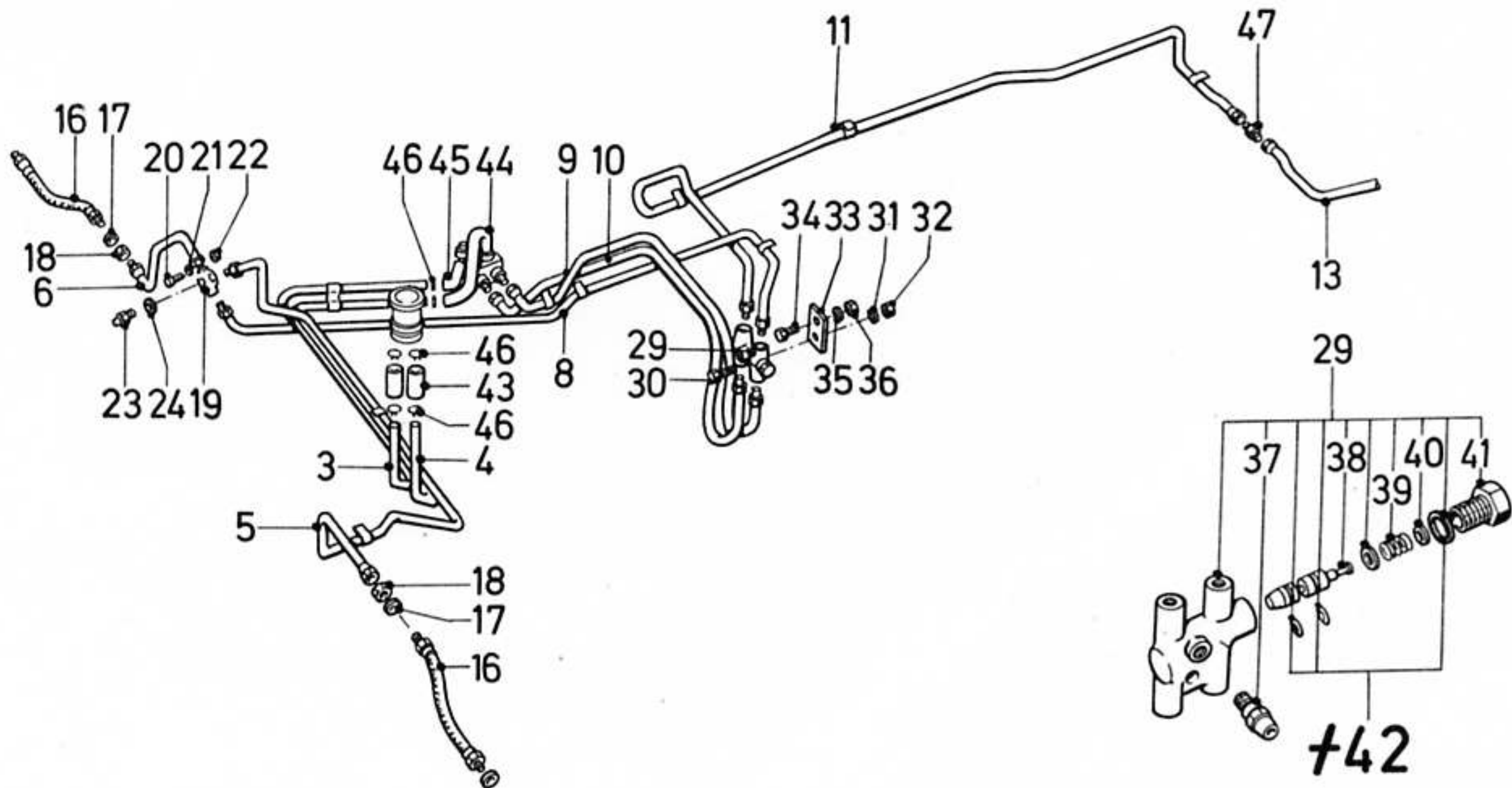
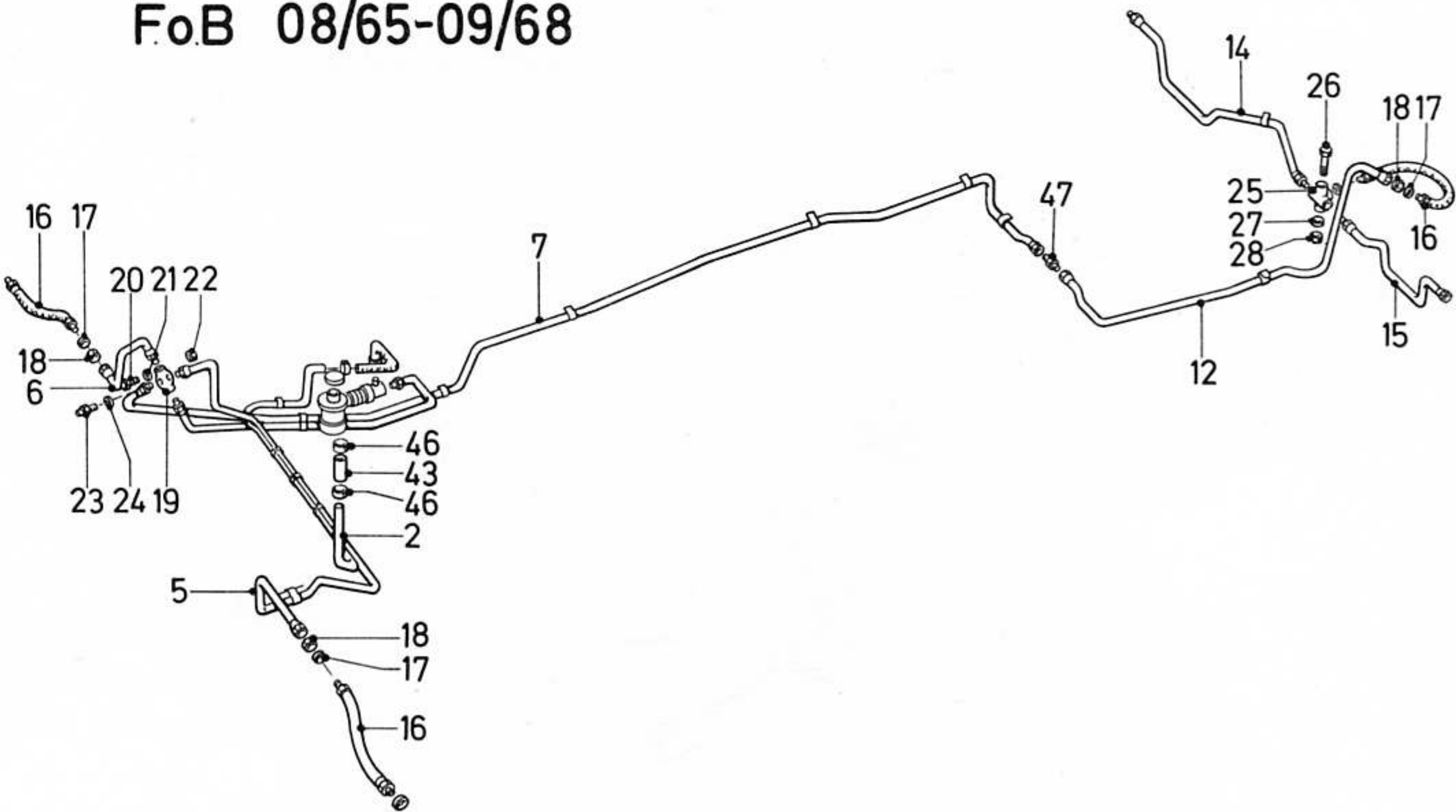

MV

F.o.B 09/68 - 12/70

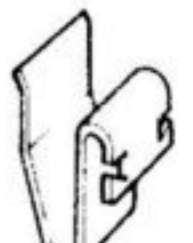
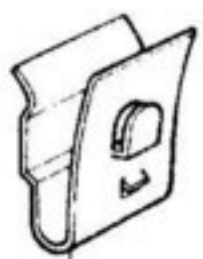
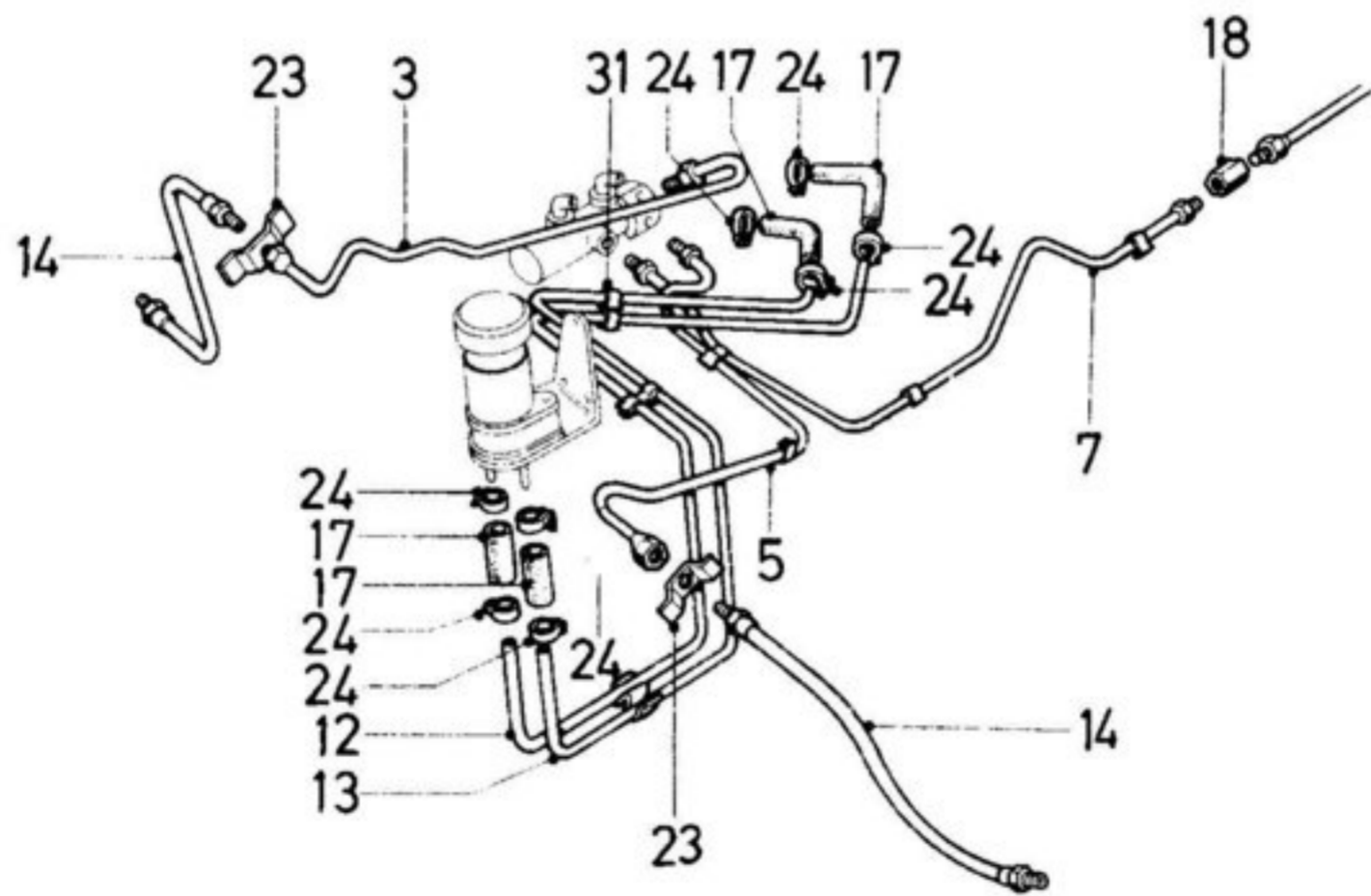
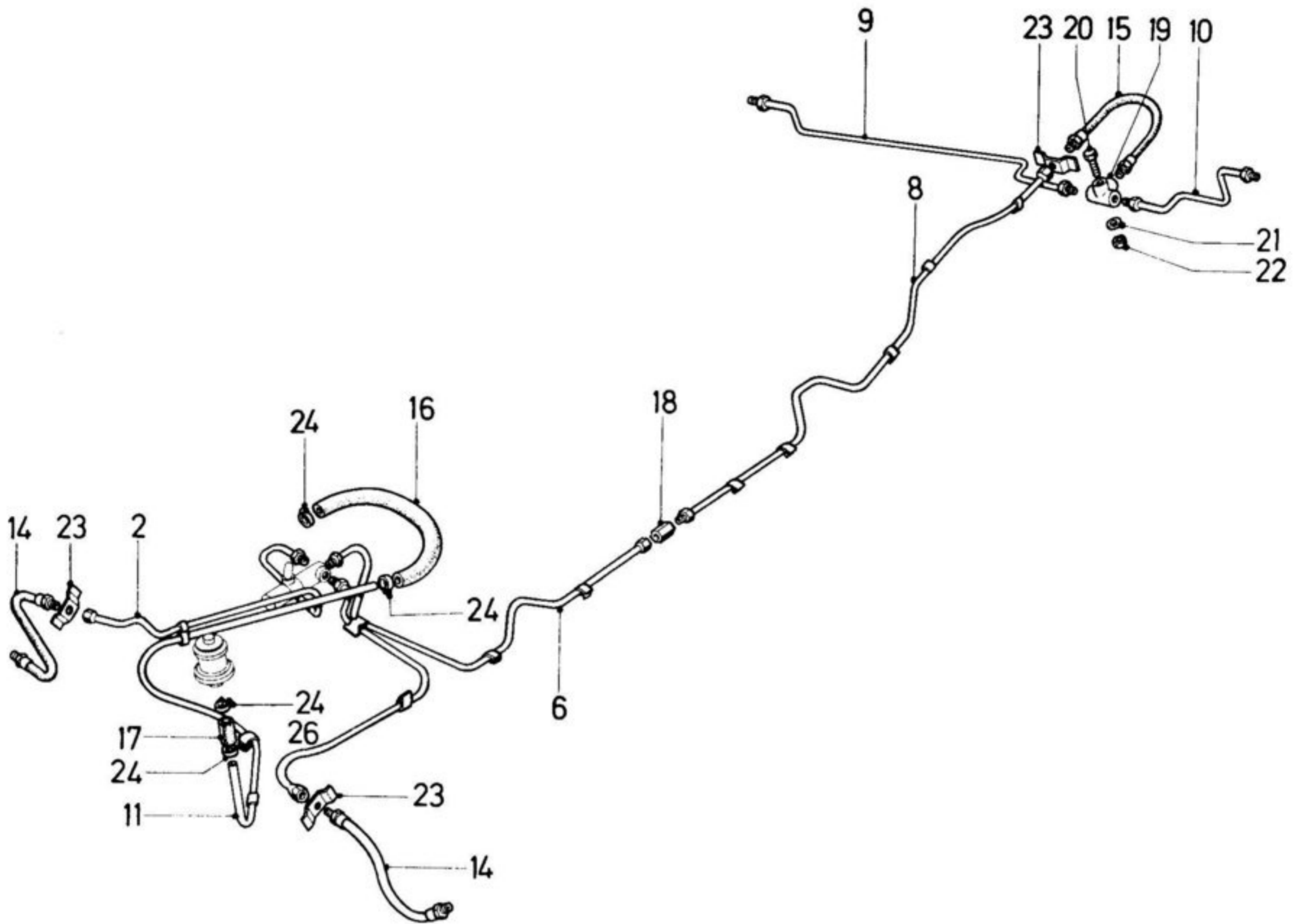

F.o.B 12/70 -

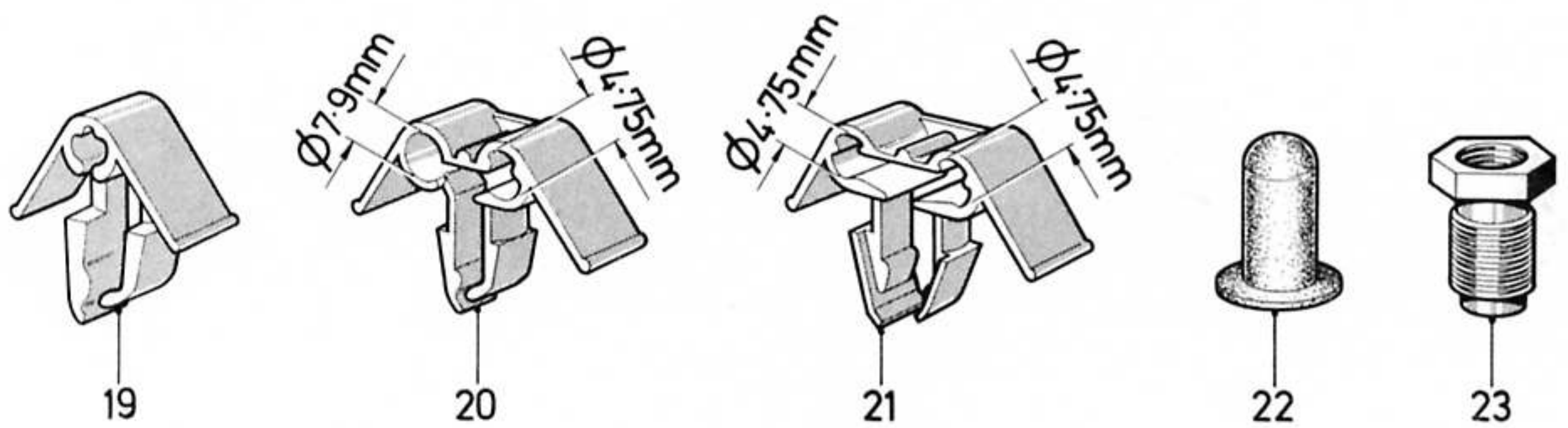
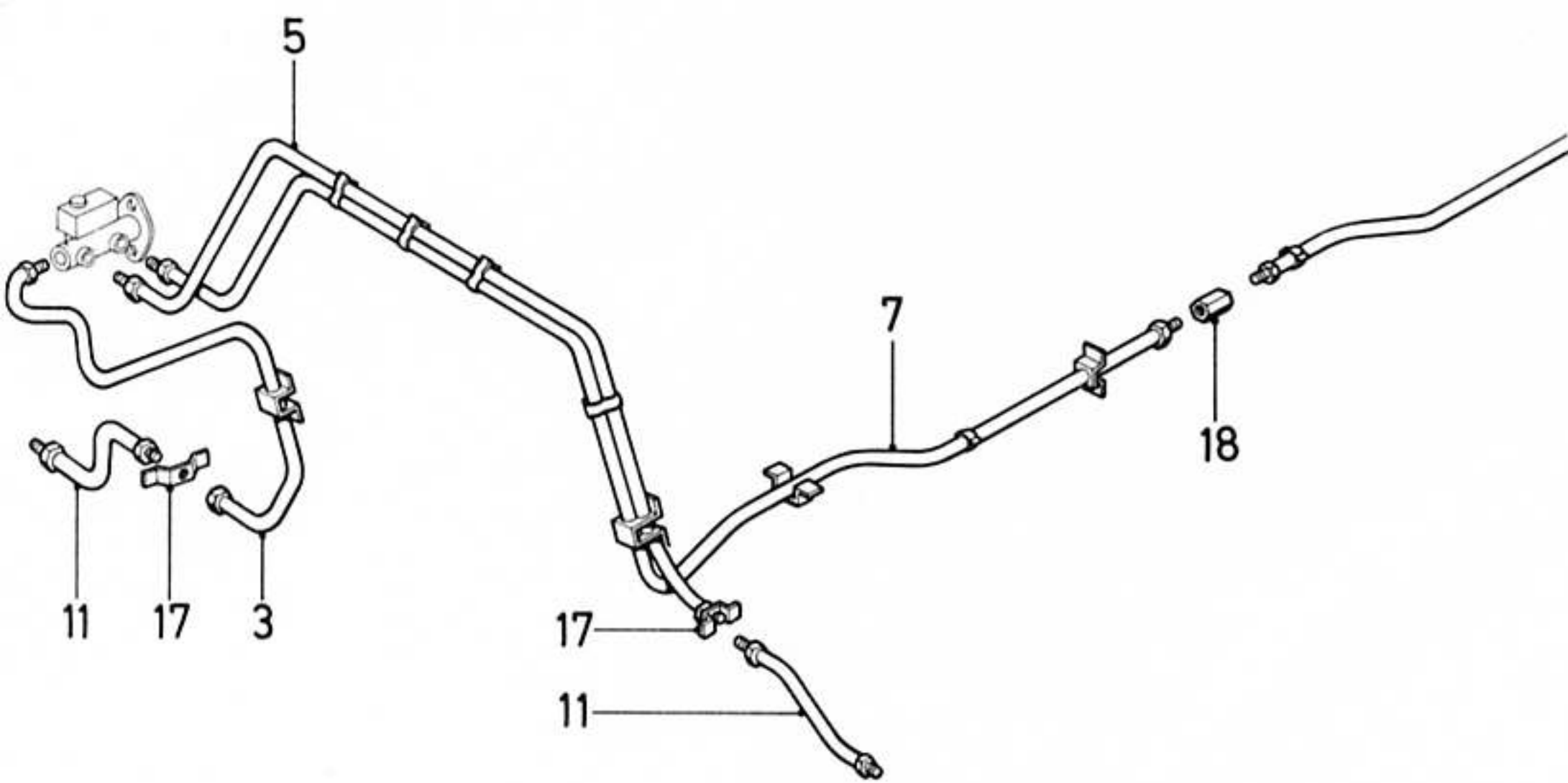
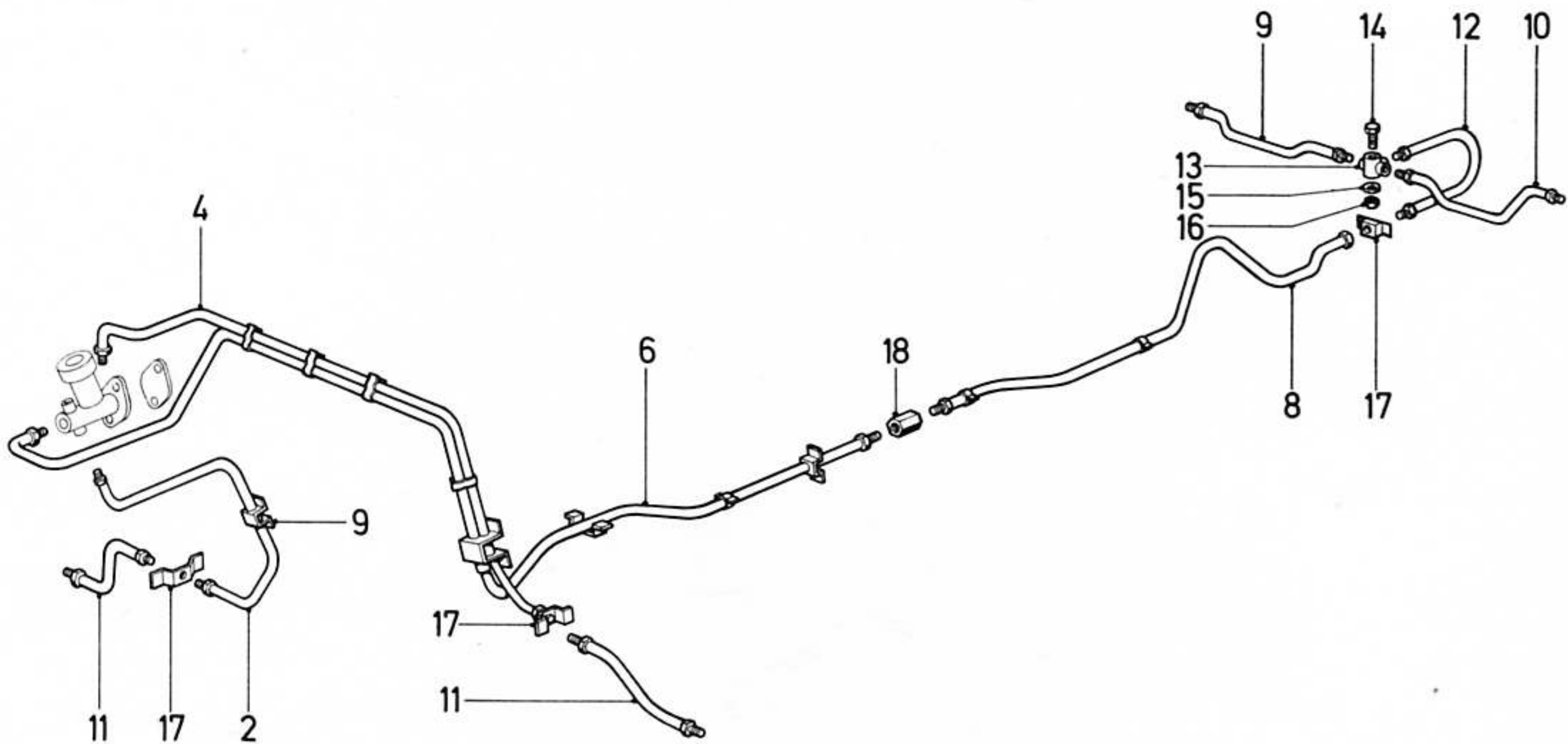

F.o.B 08/65-09/68

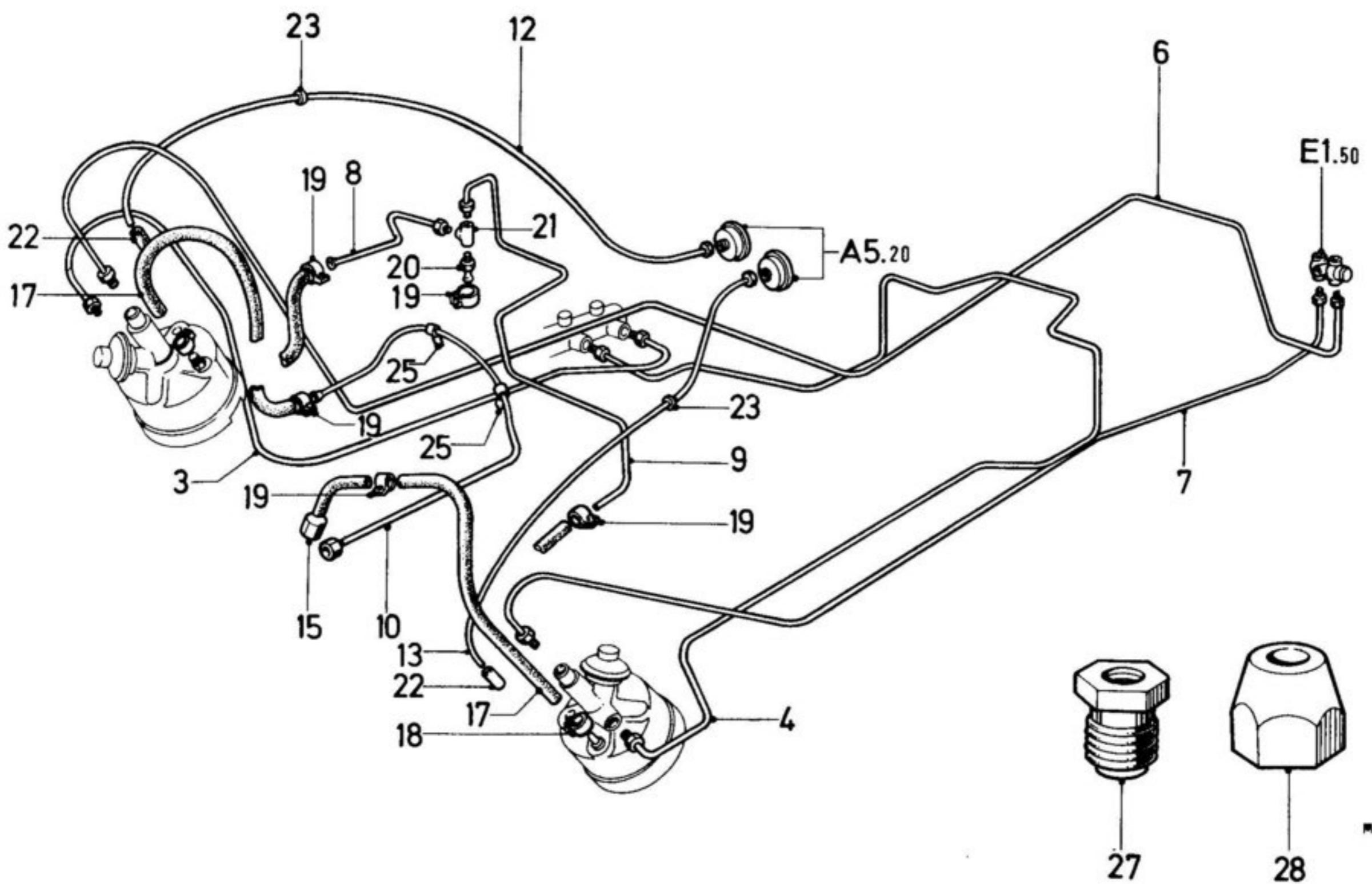
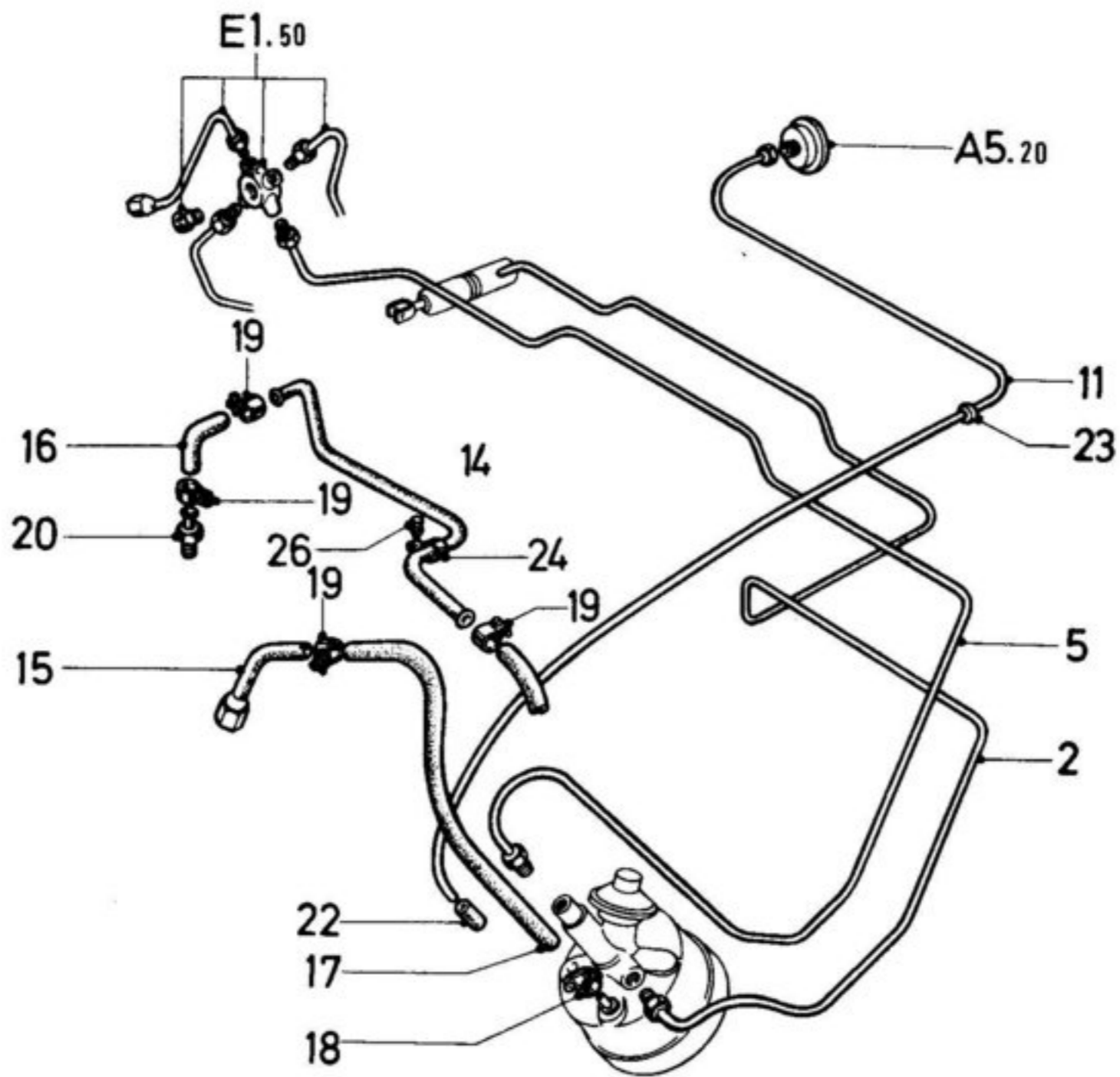

F.o.B 09/68 - 12/70

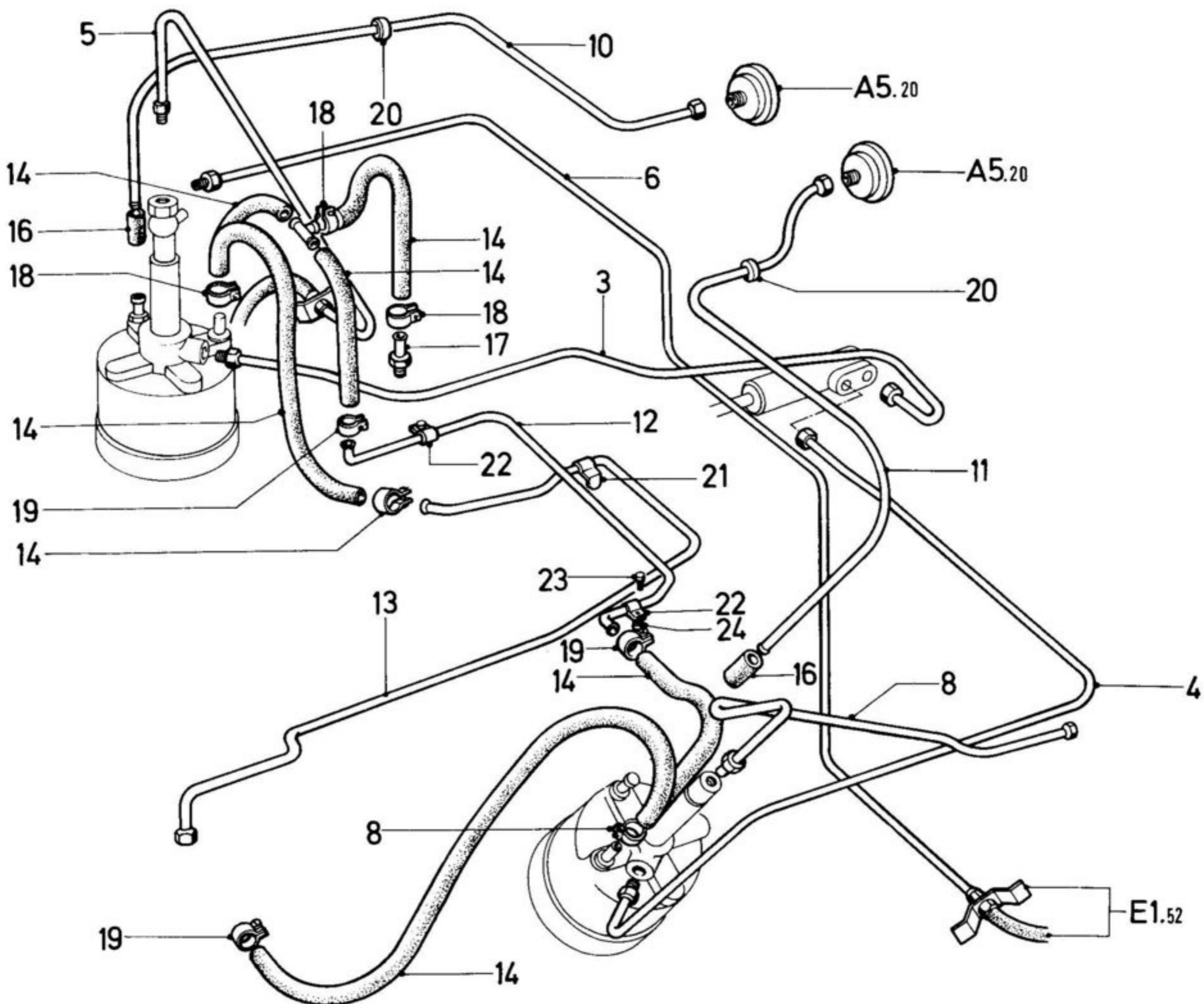
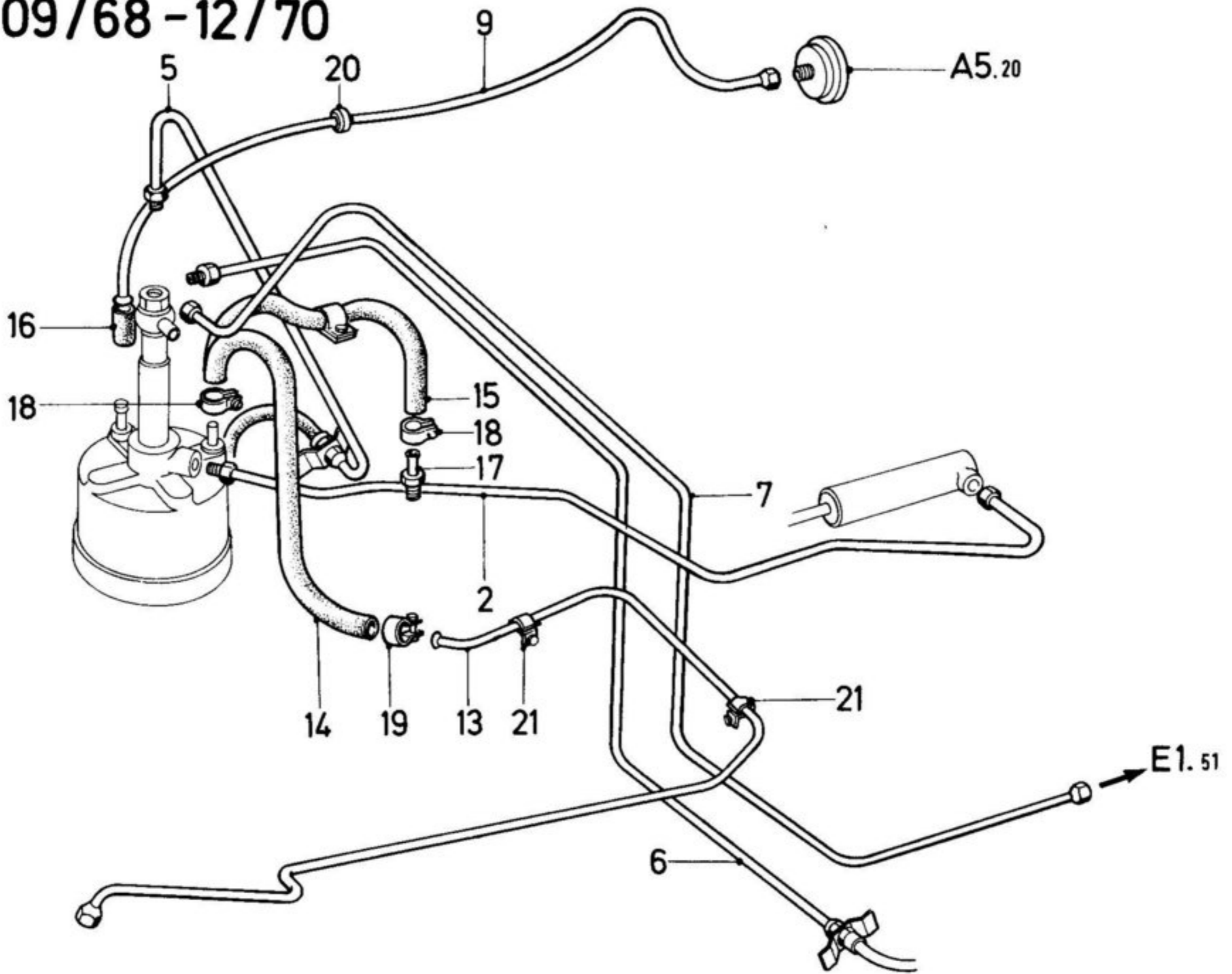

F.o.B 12/70-

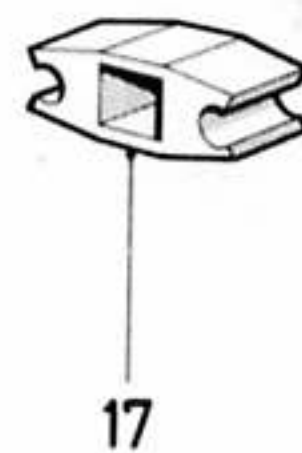
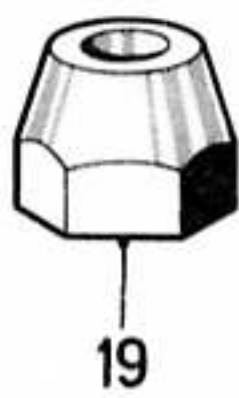
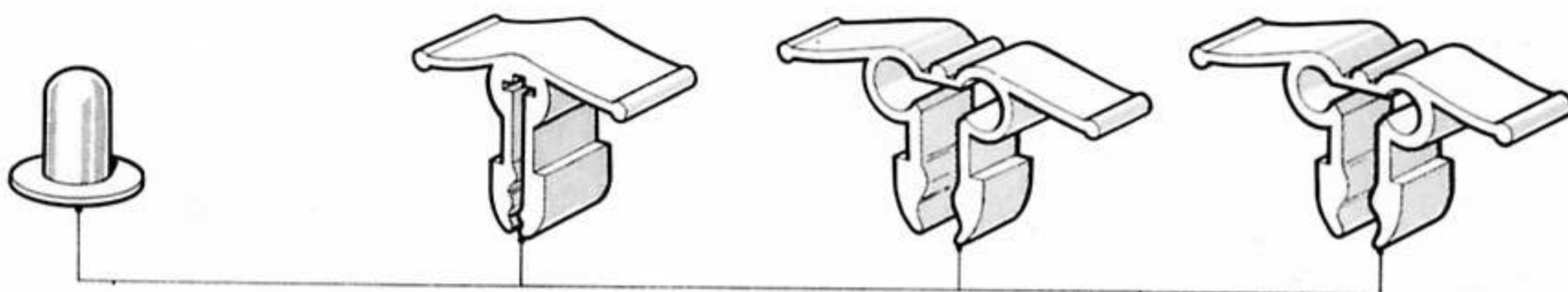
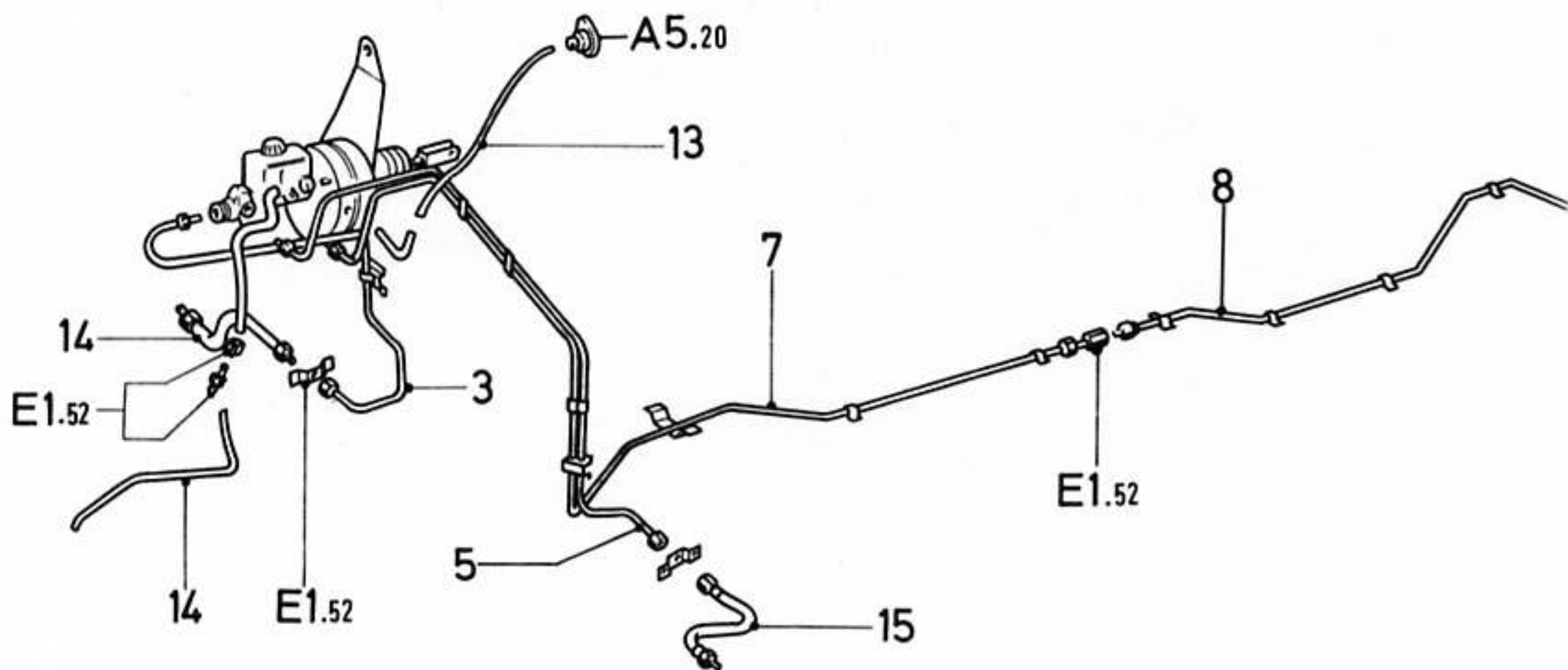
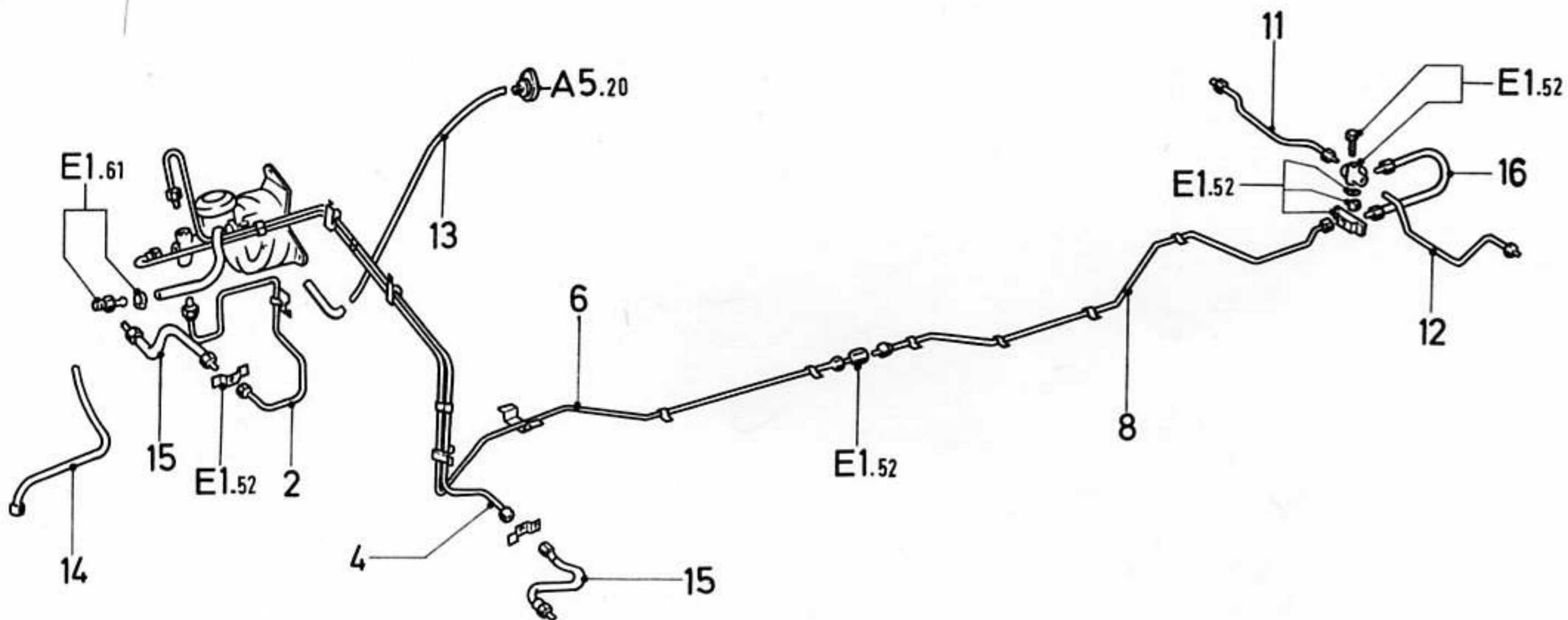
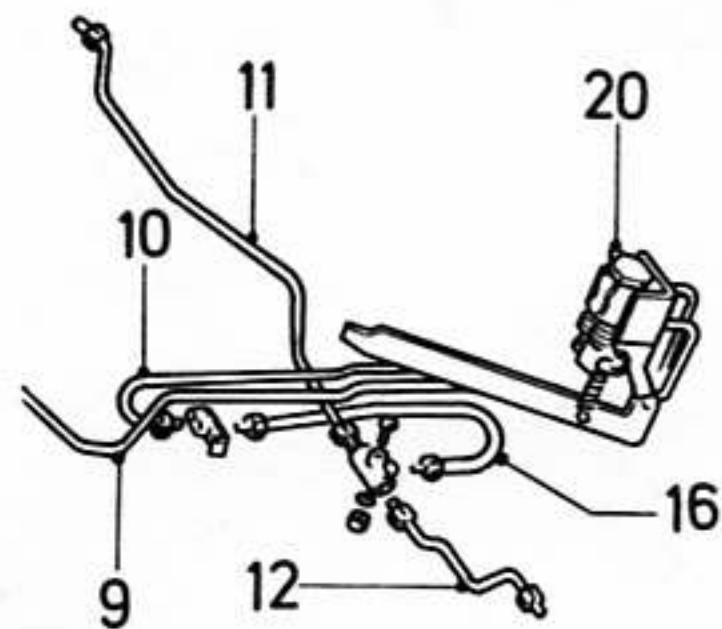

F.o.B 12/71

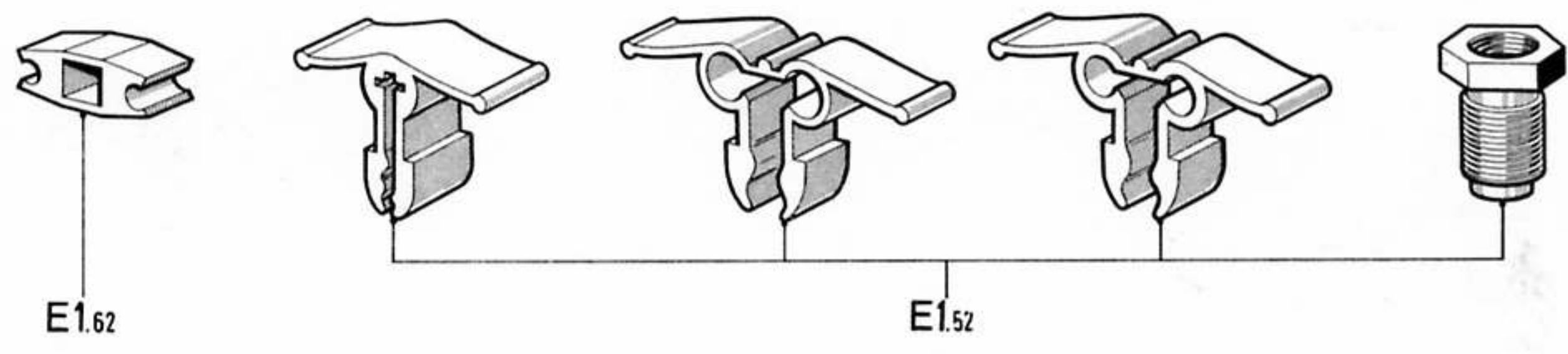
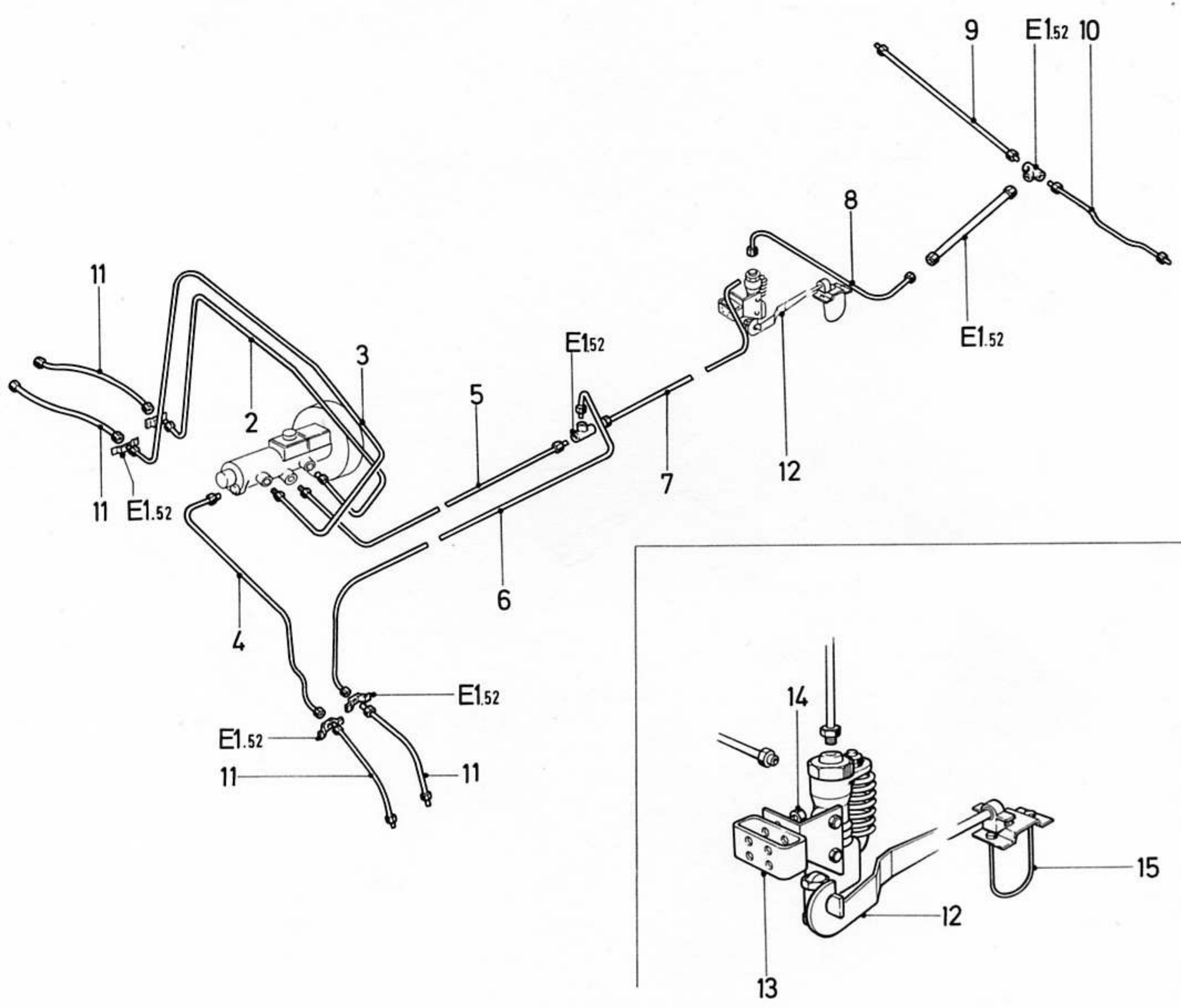

F.o.B 11/73 -

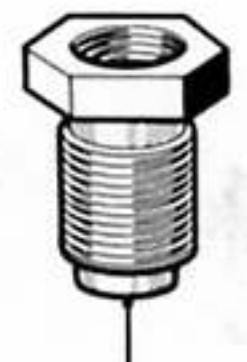
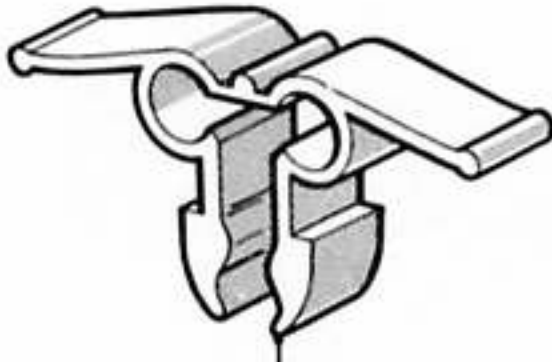
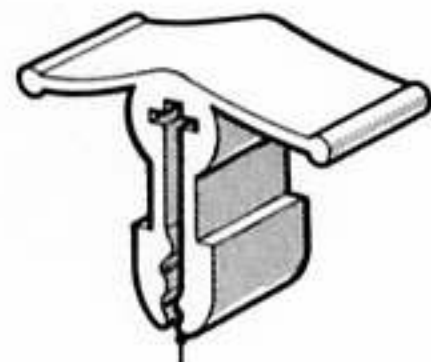
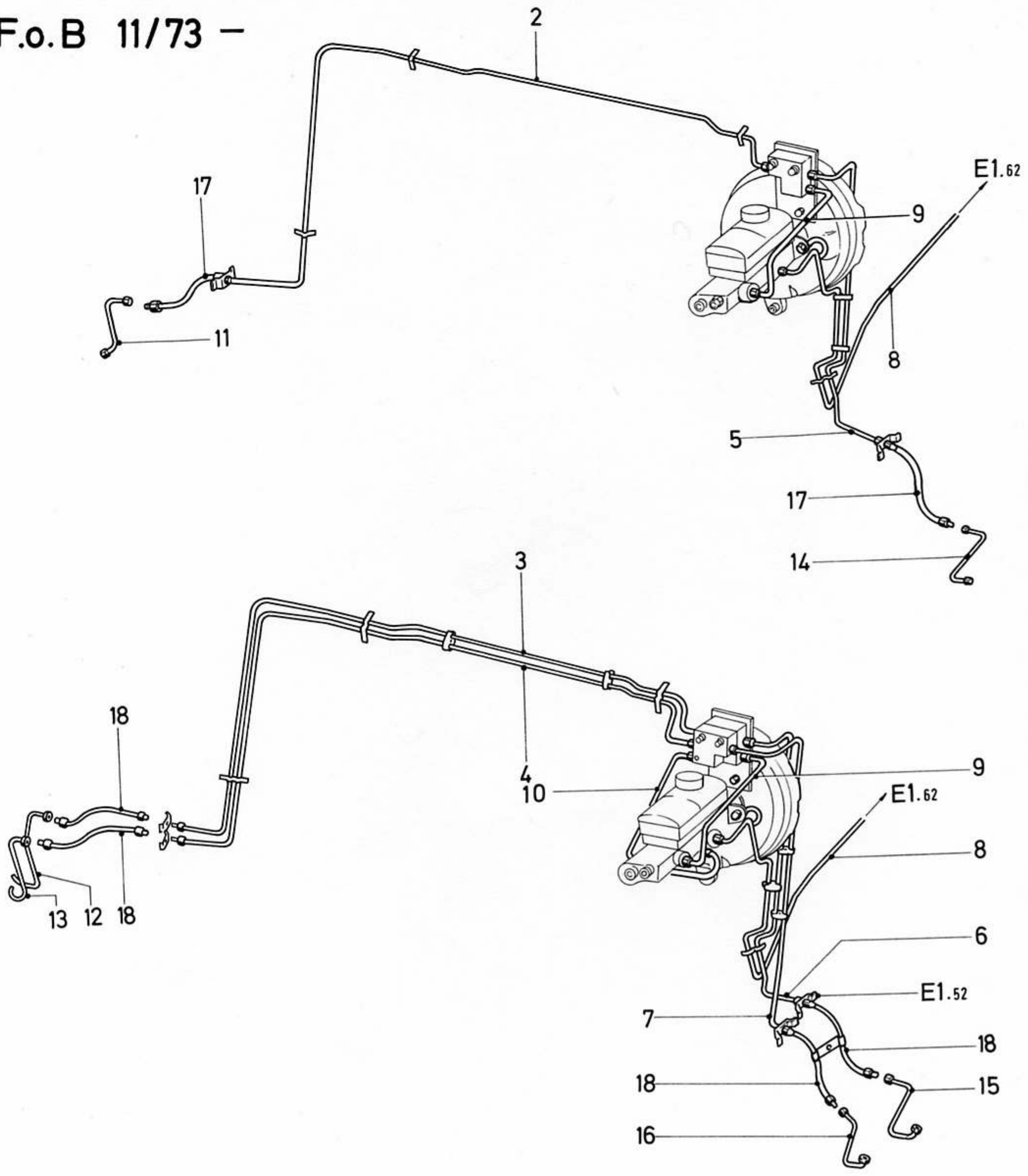

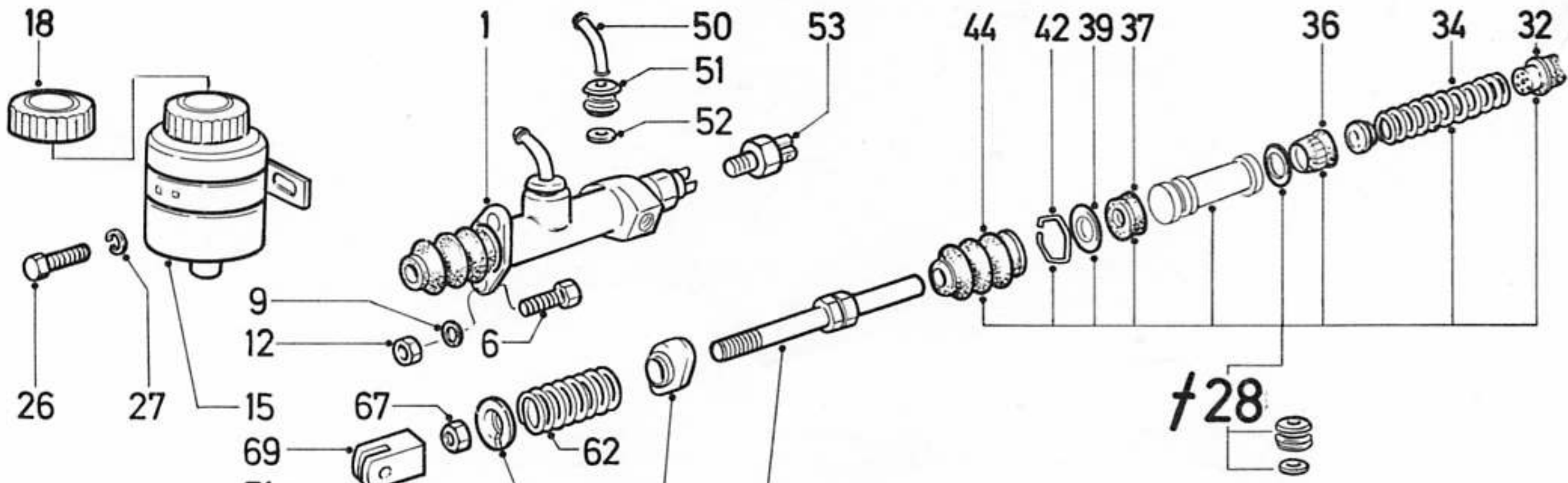

F.O.G 09/65-11/68

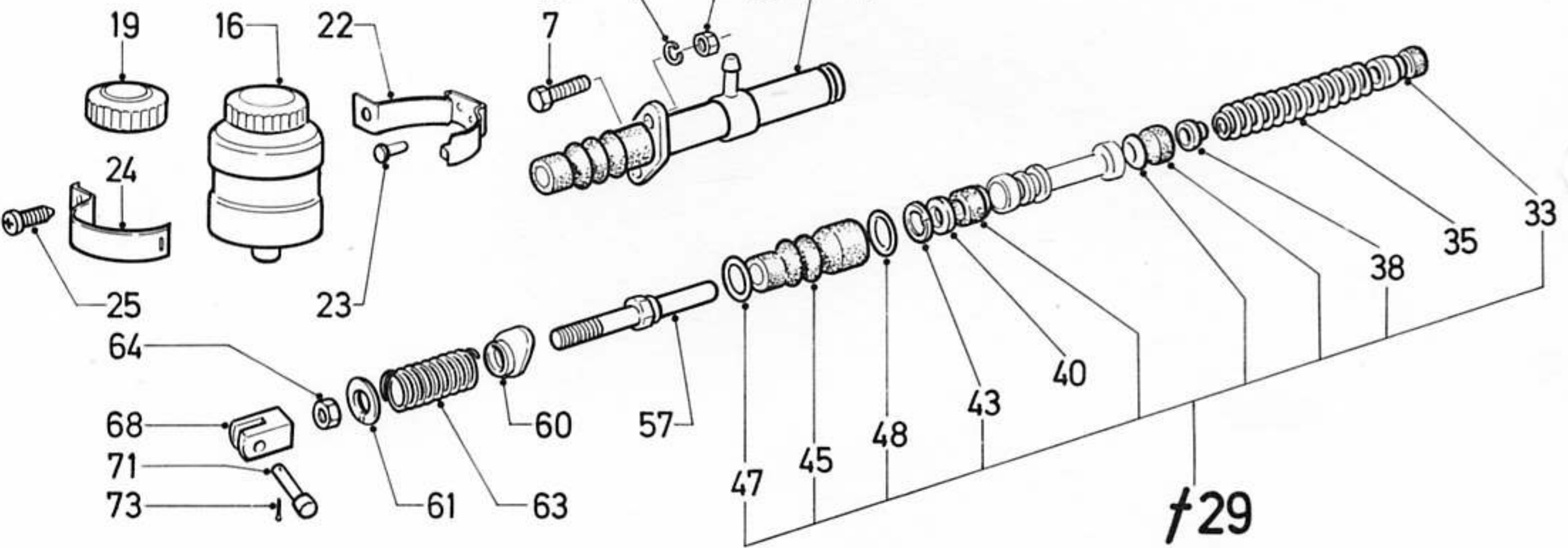

F.O.B 08/65-09/68

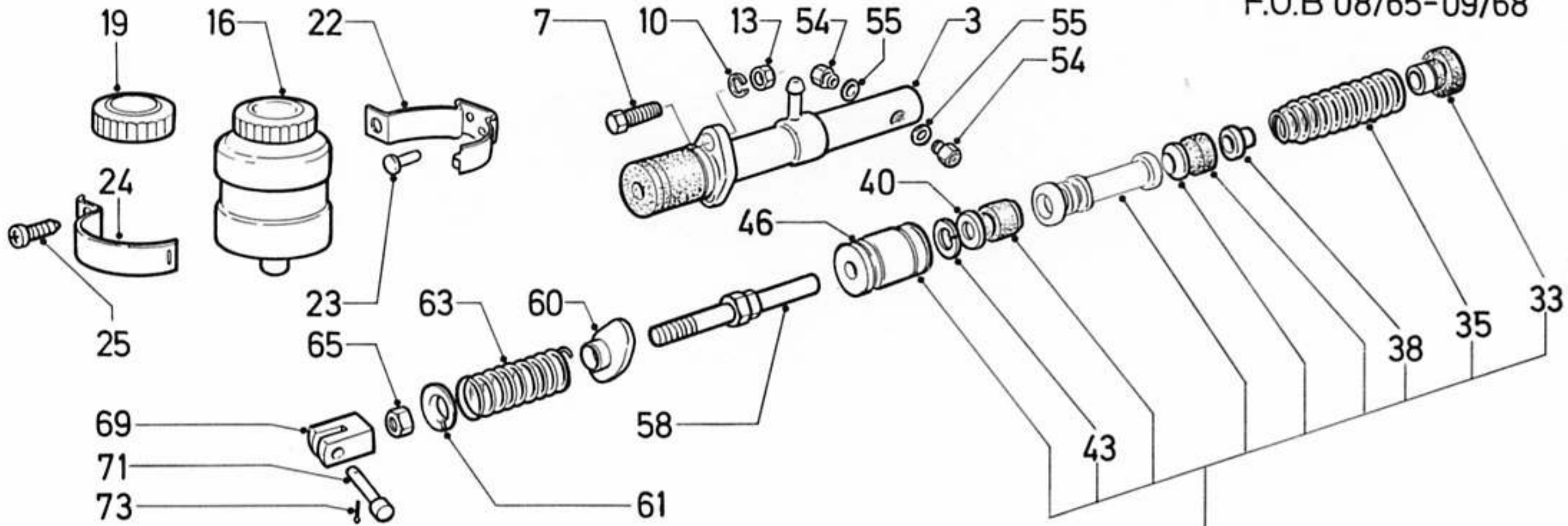

F.O.B 09/68-12/70

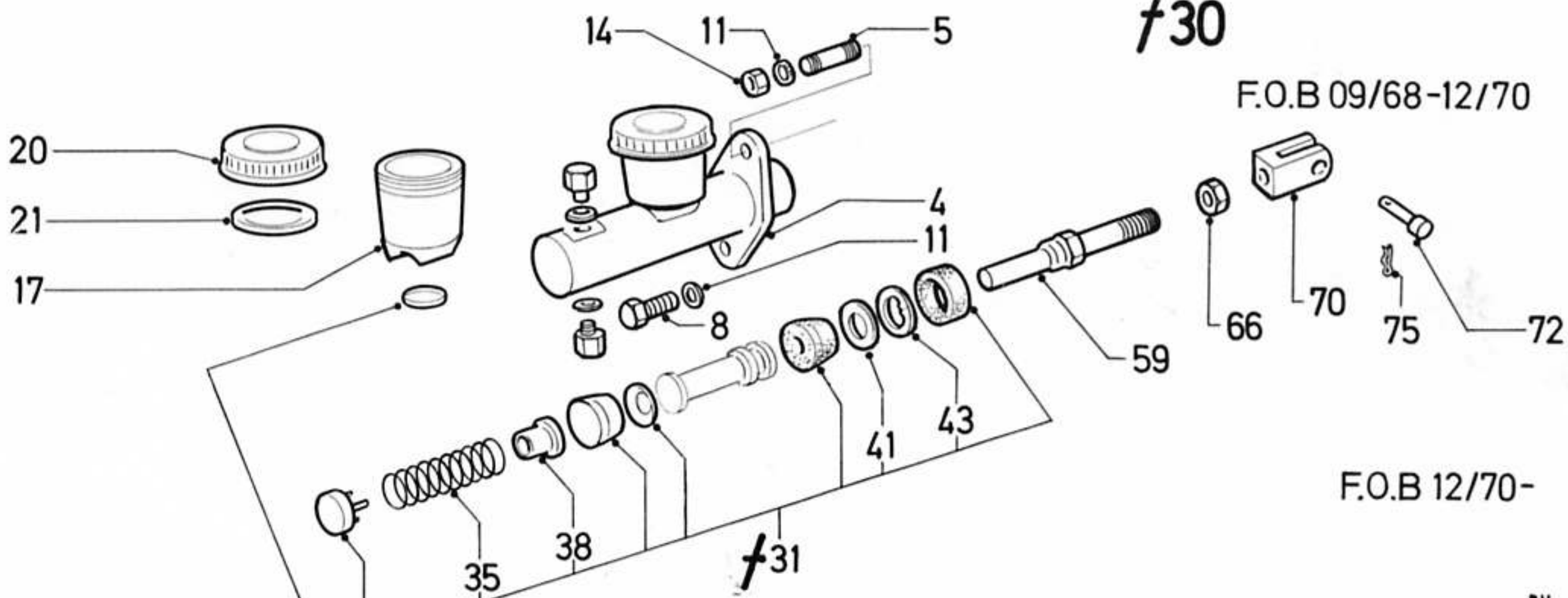

F.O.B 12/70-

09/65-12/70

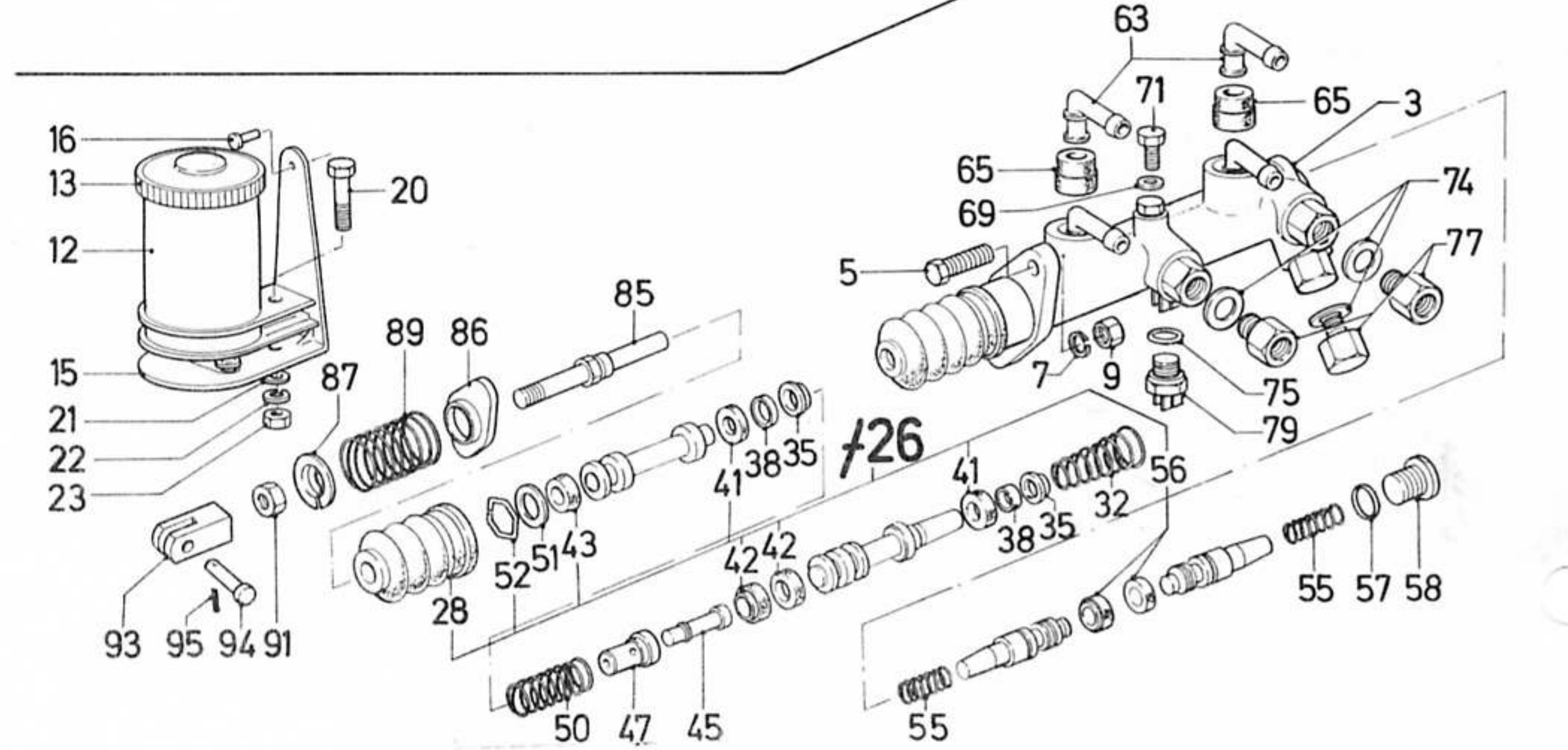
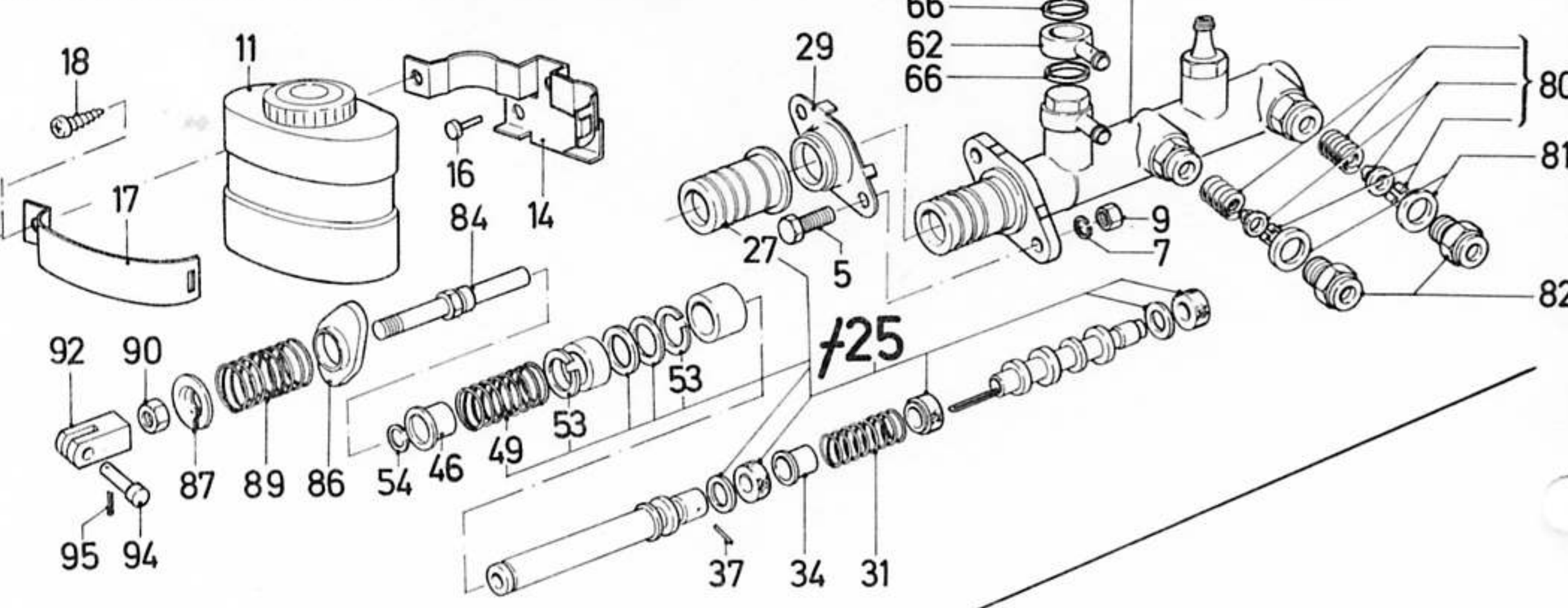
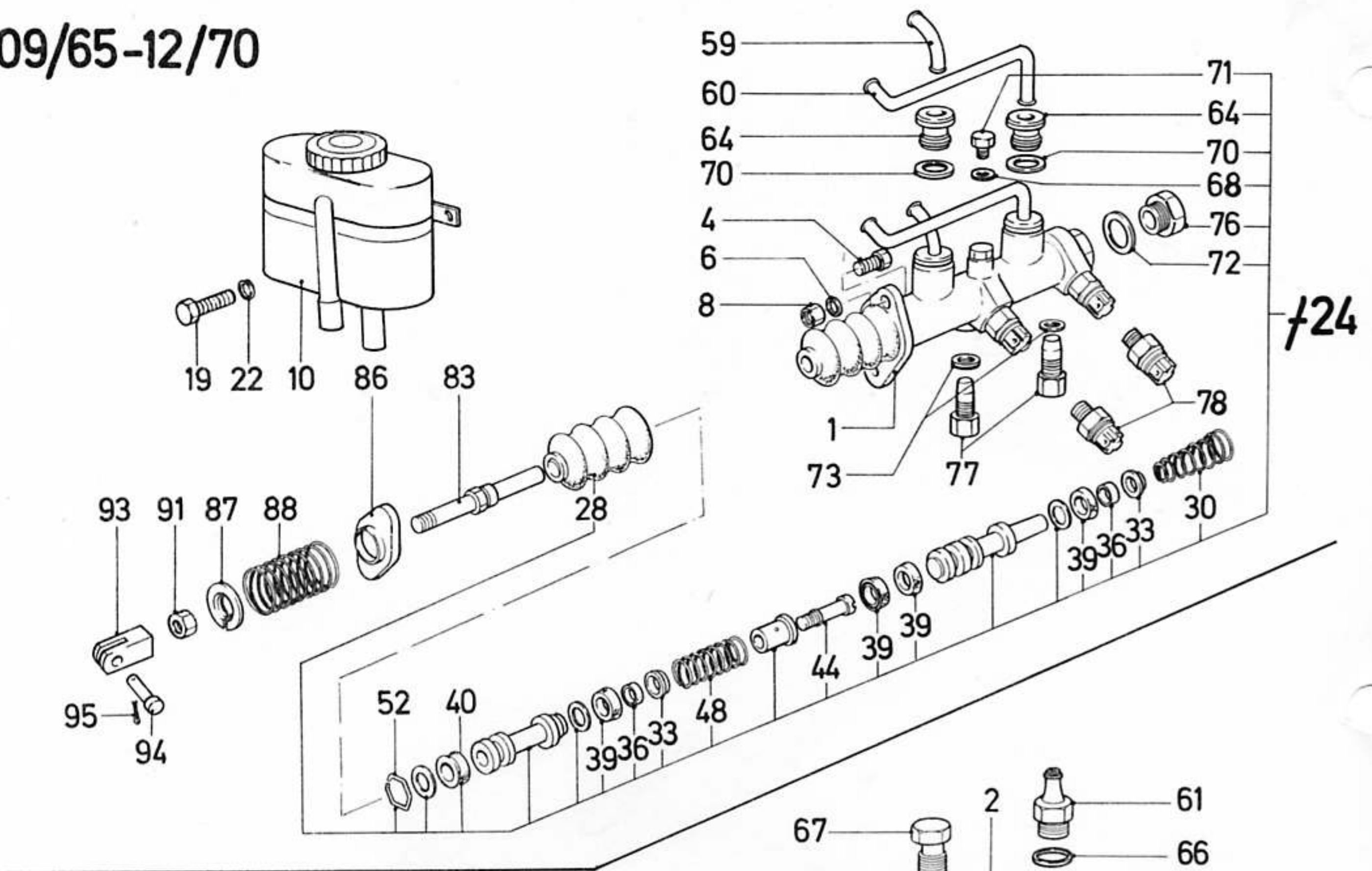

12/70-

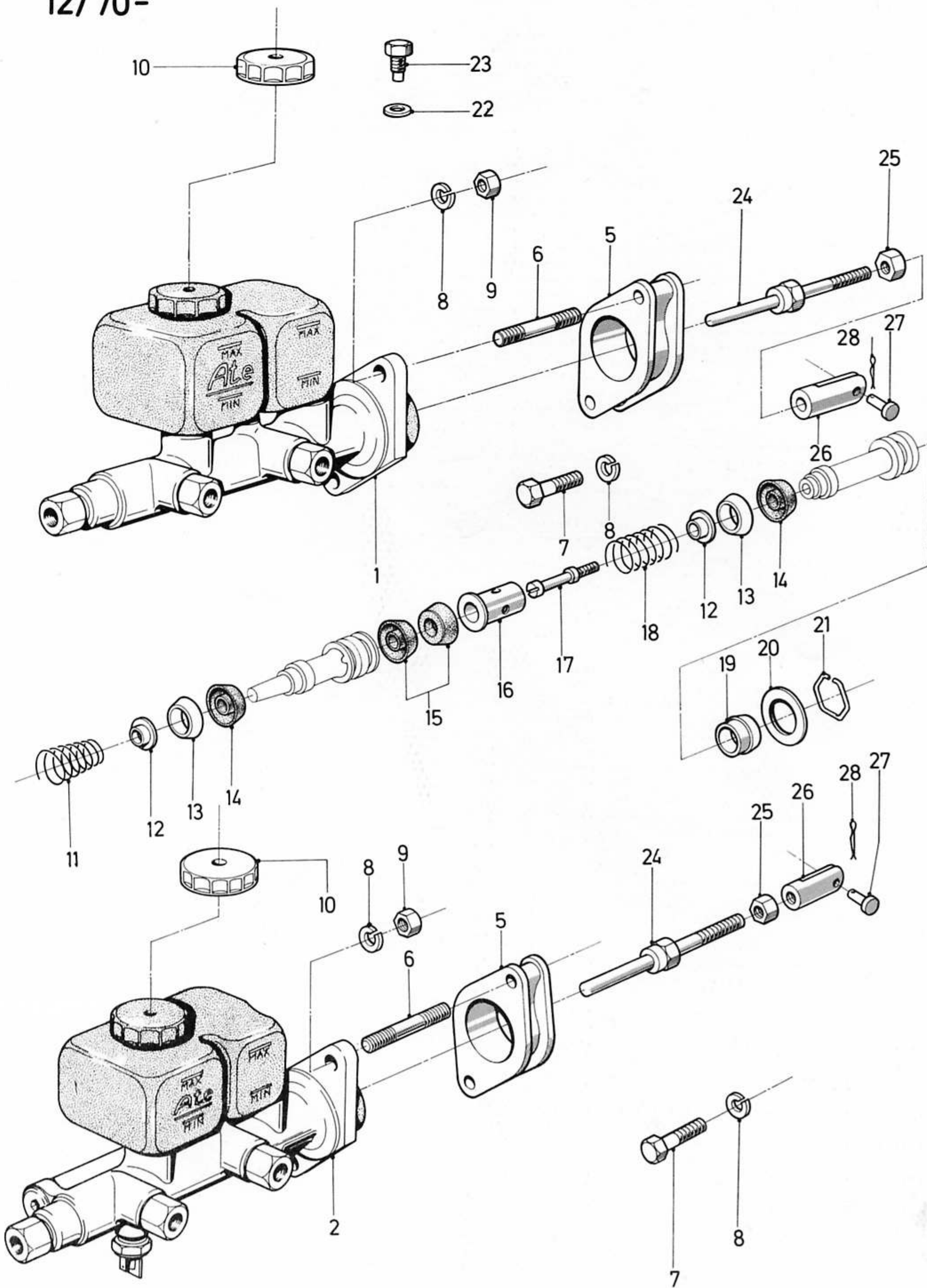

09/65-11/68 F.o.G.

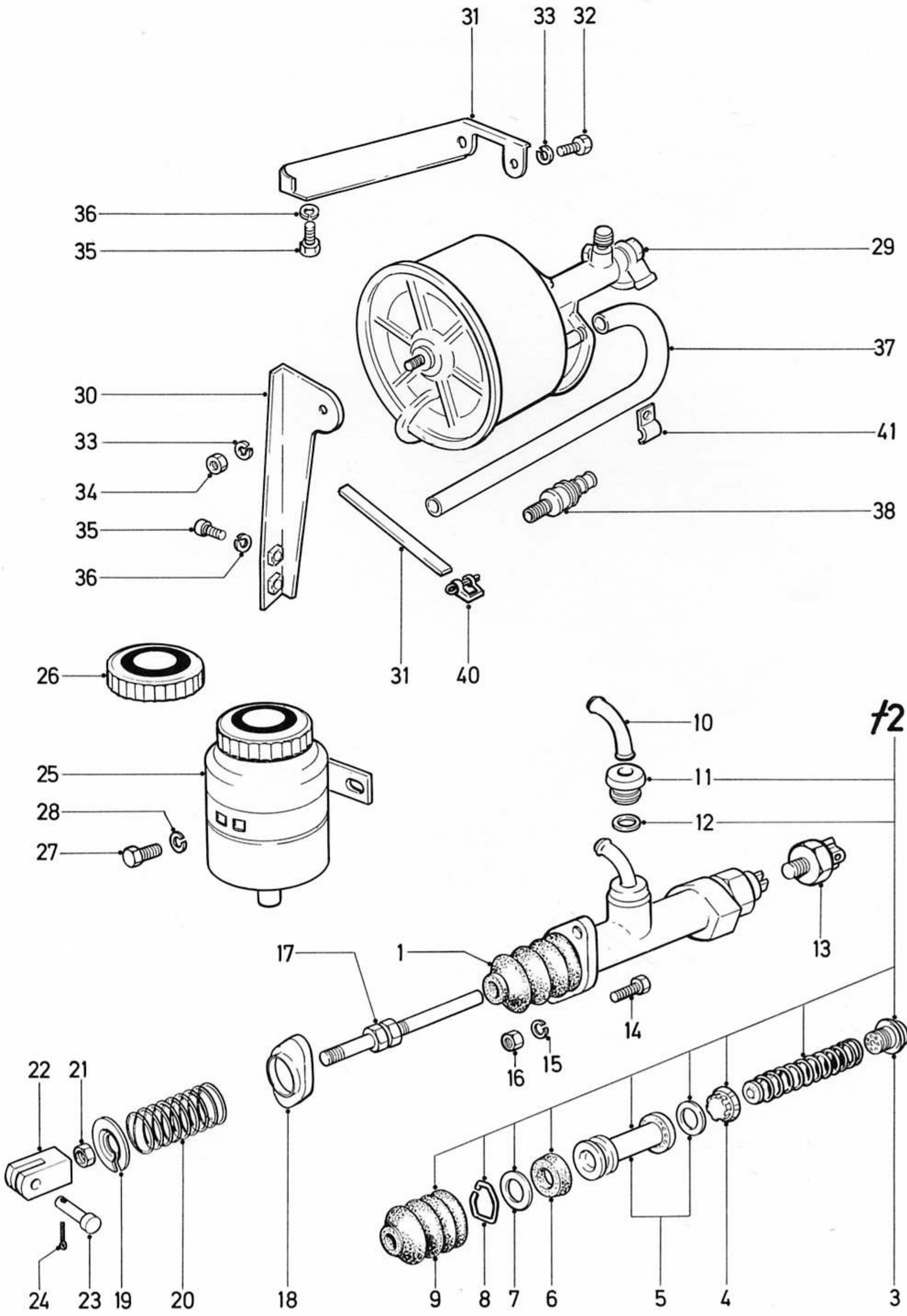

f2

11/68 - 12/70 F.o.G.
08/65 - 12/70 F.o.B.

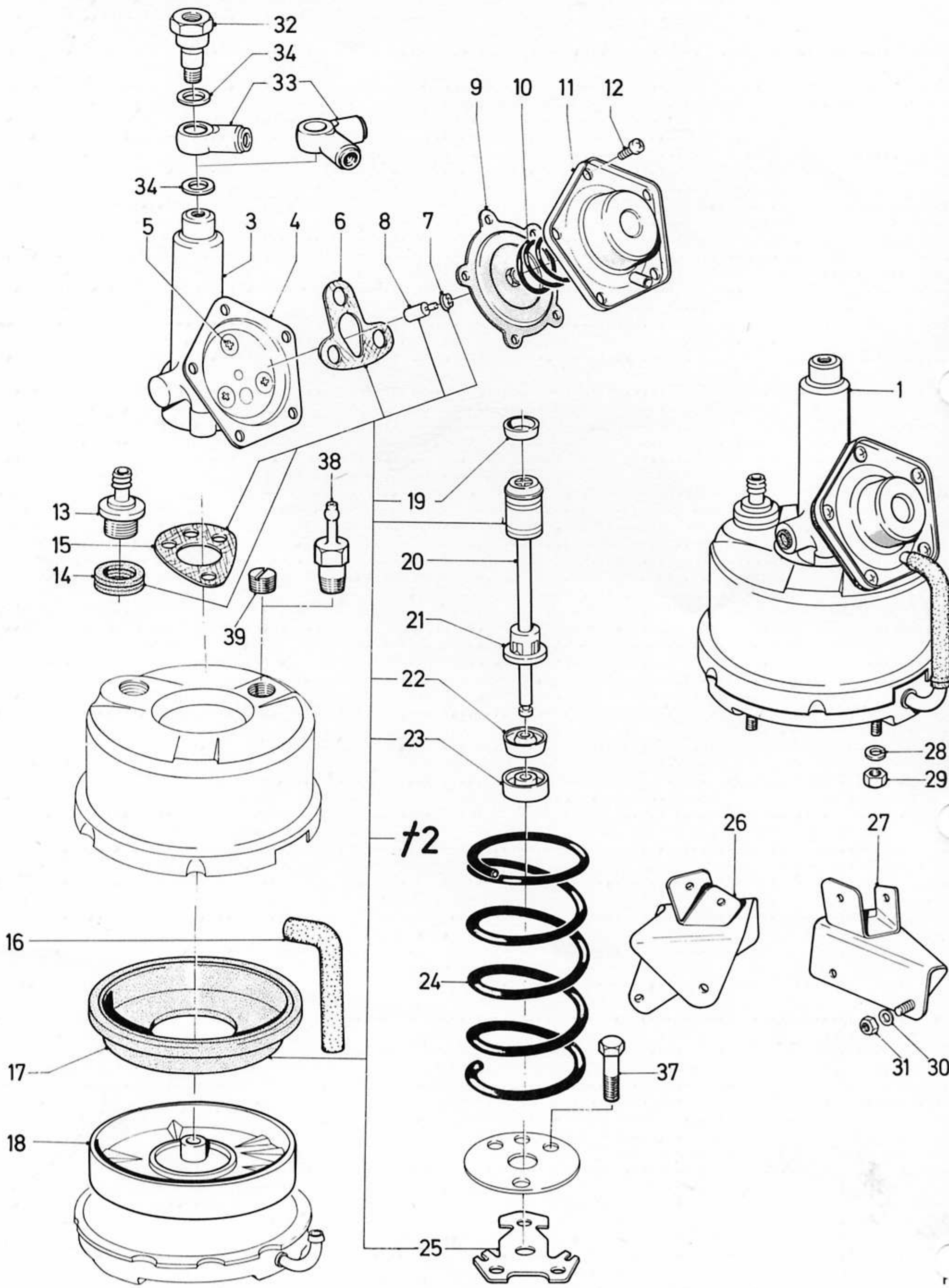

12/70-

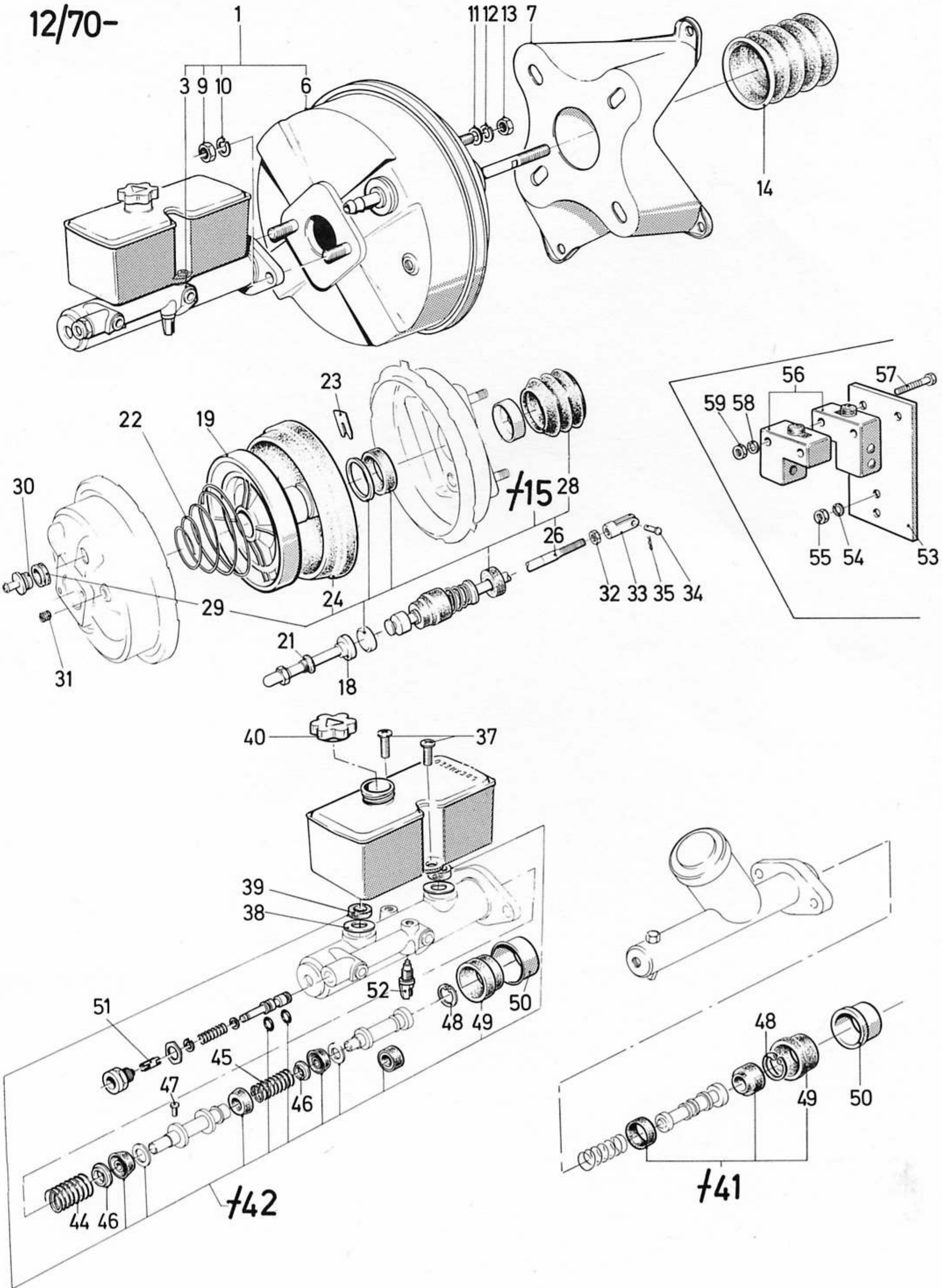

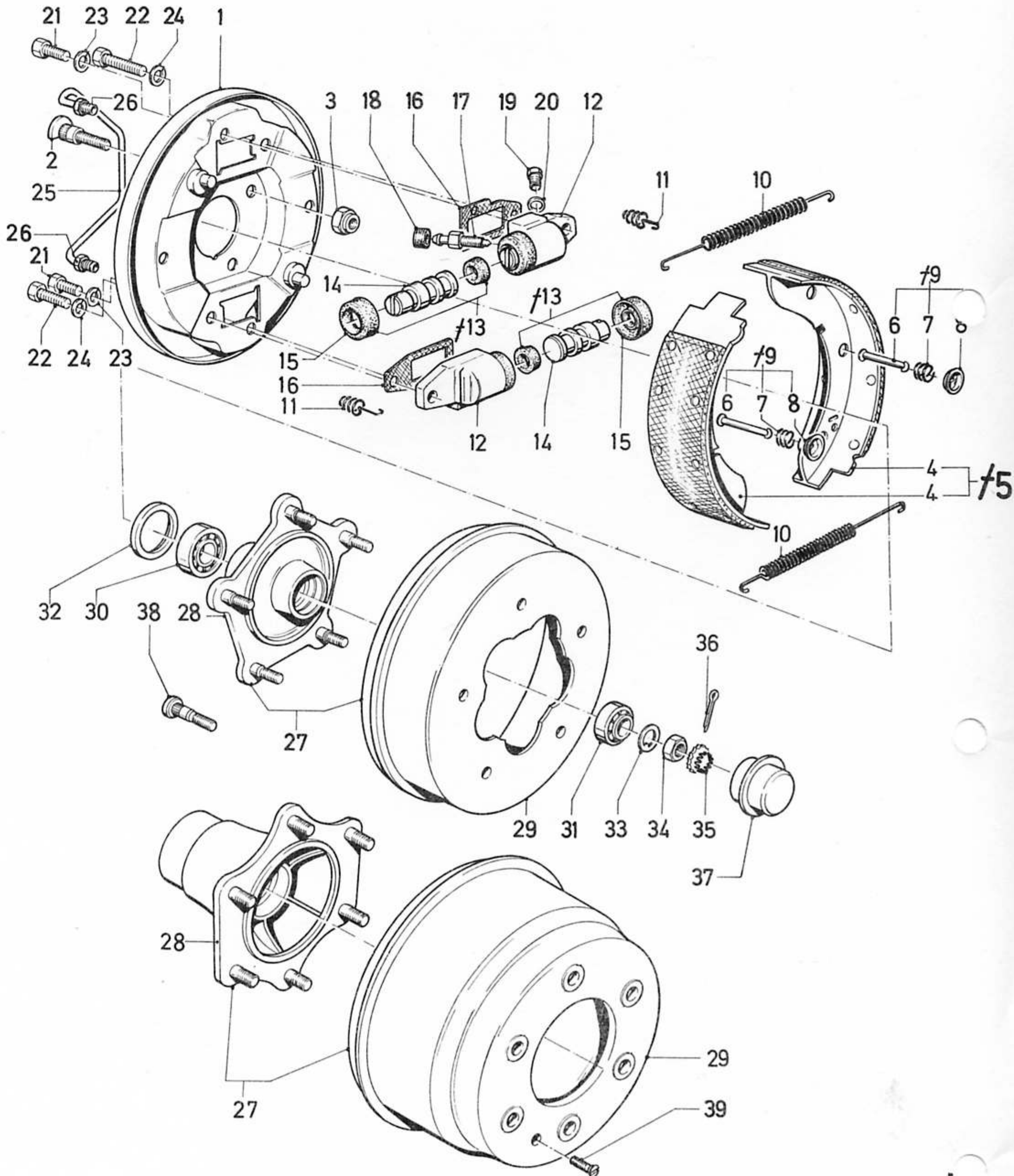

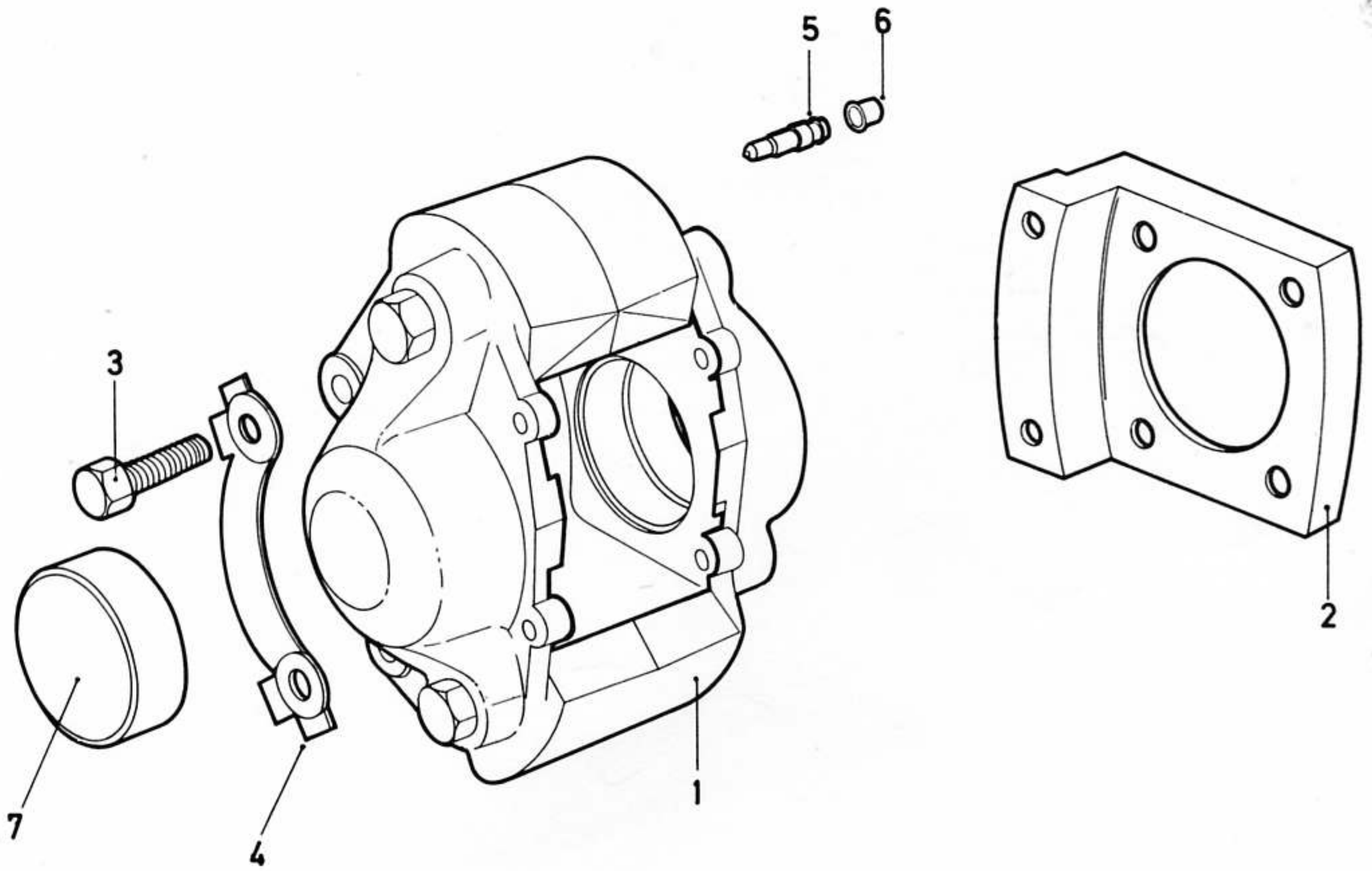

78

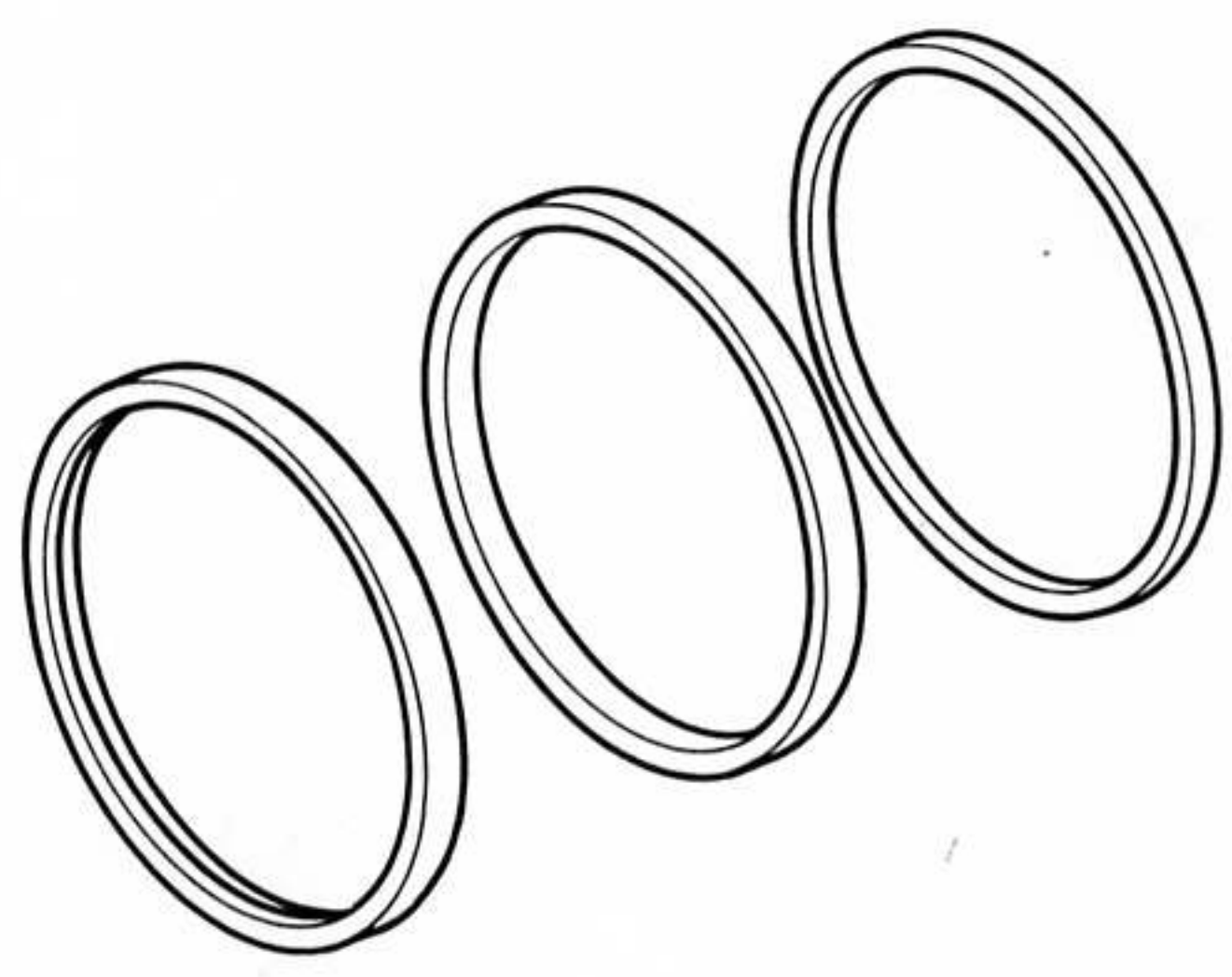

79

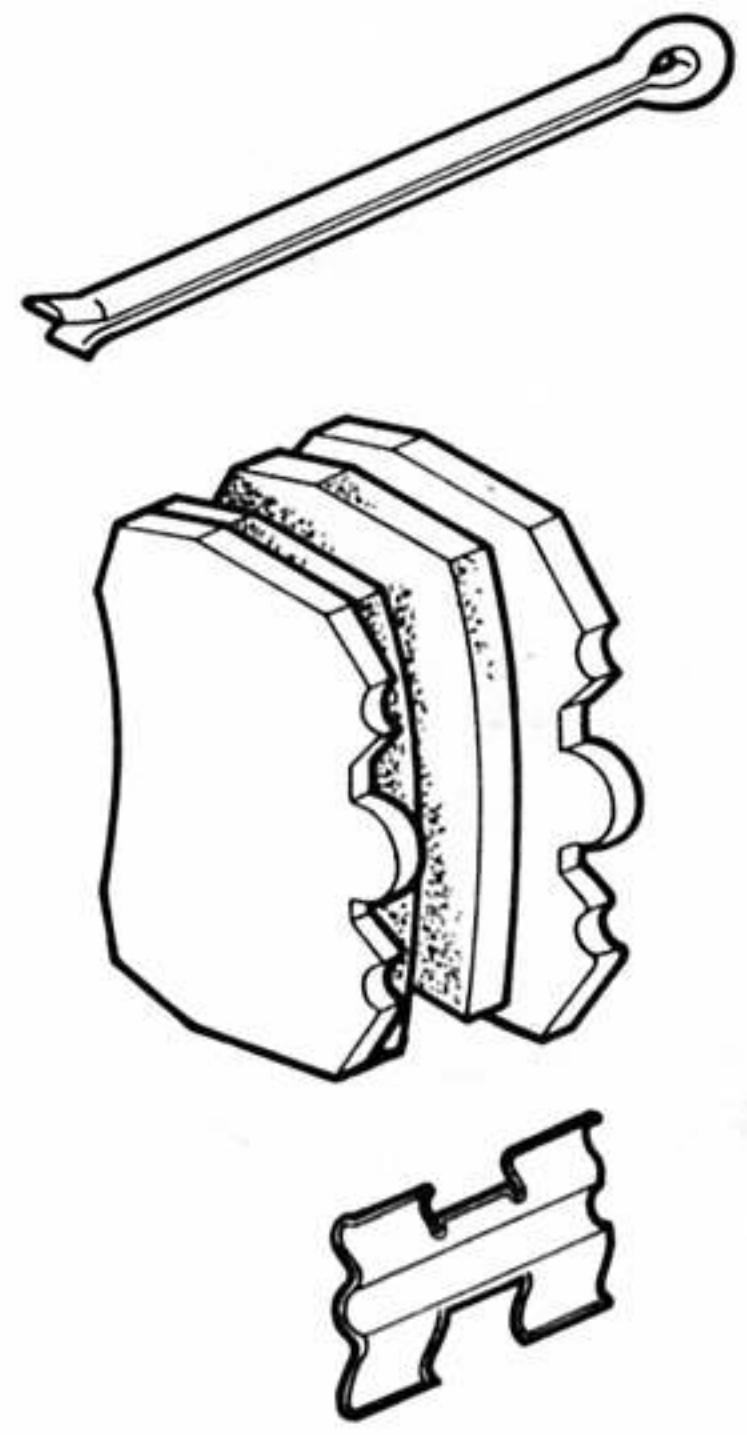

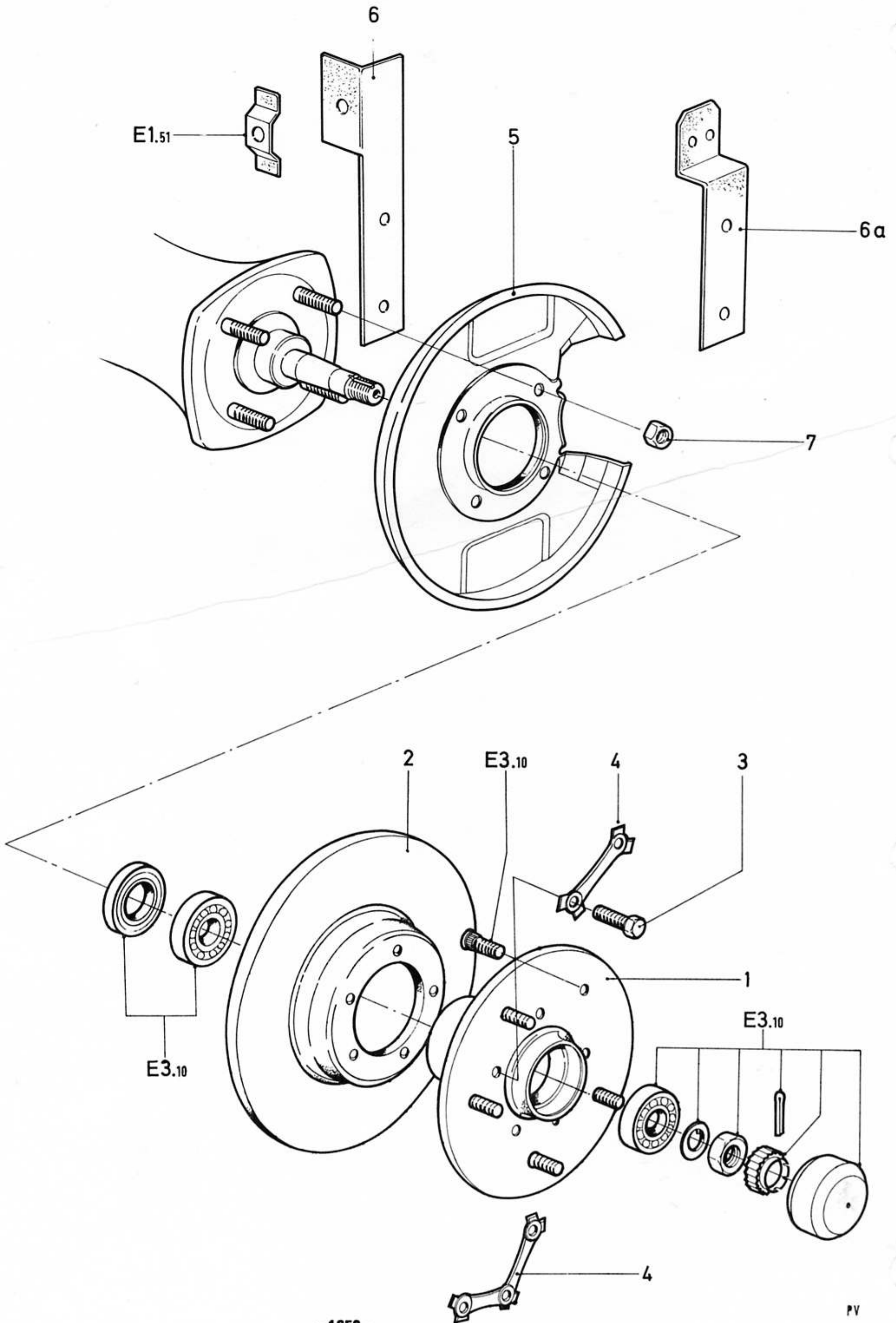

60-110

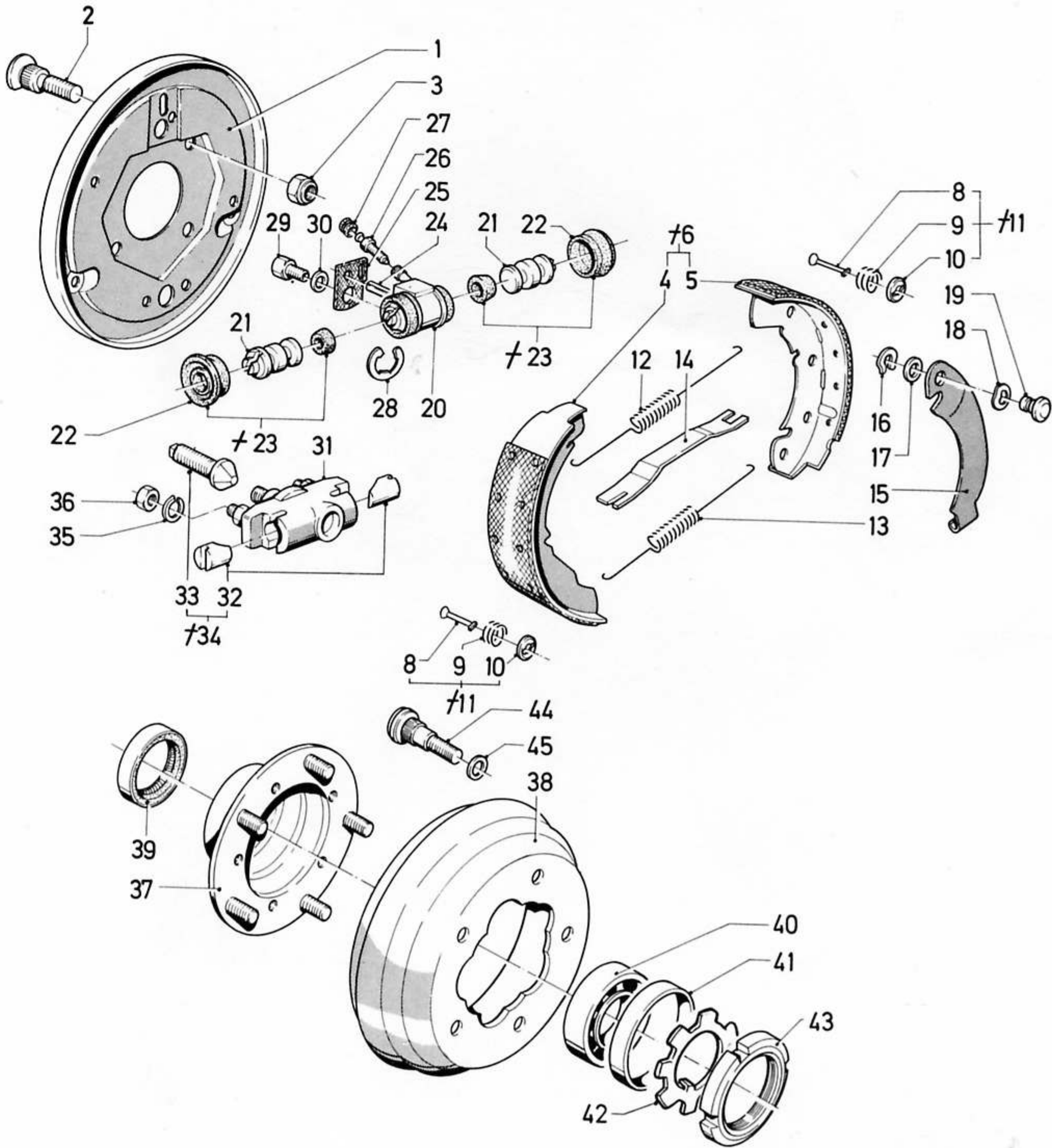

125-175

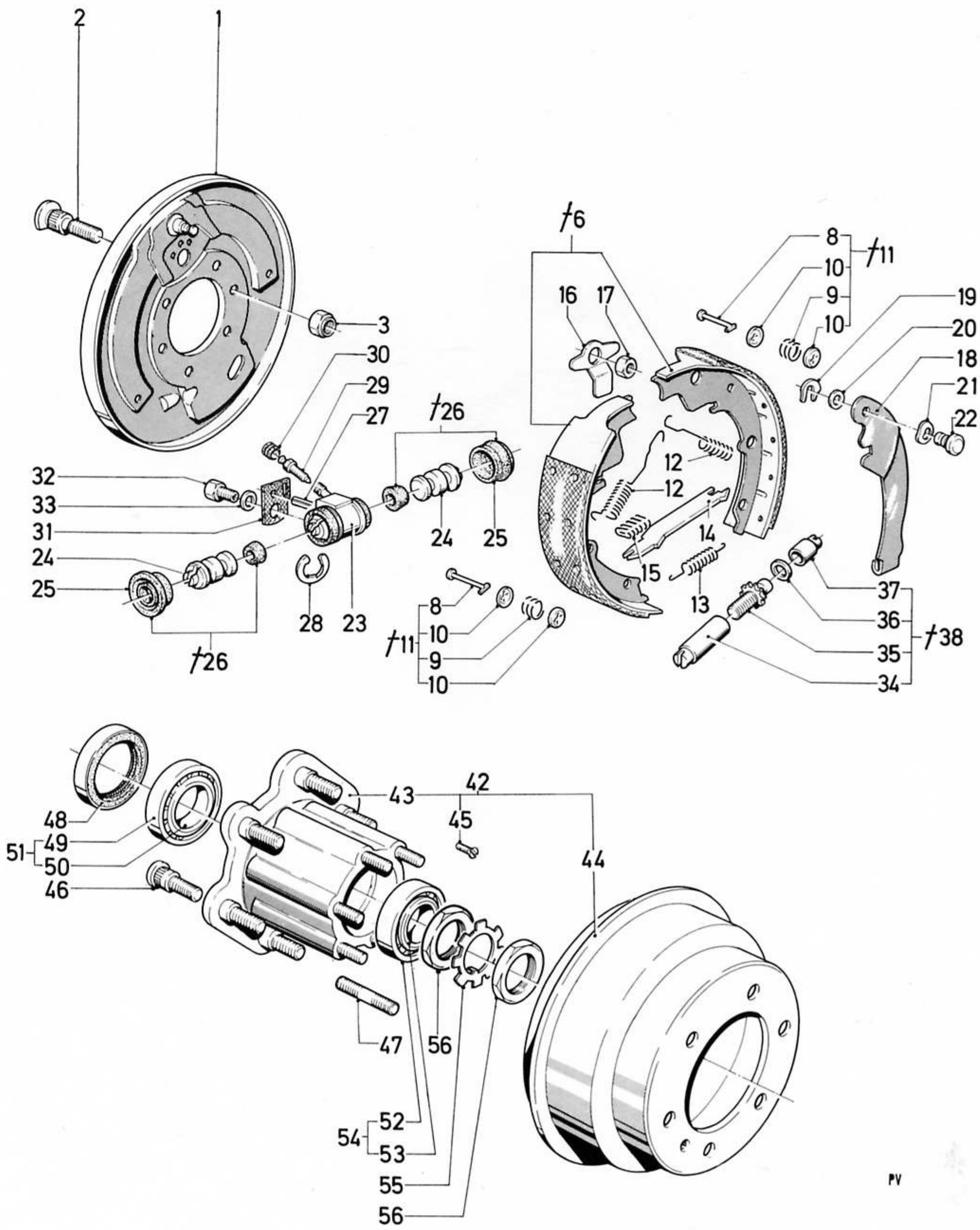

PV

60-125

